

# Soft Magnetic Applications Guide

---



## Table of Contents

### Introduction and Basics of Magnetics

Introduction .....	3
Basics of Magnetics.....	3
Units of Measure .....	3
Simple Magnetic Theory .....	3
Permeability .....	5
Saturation .....	5
BH (or Hysteresis) Loop.....	5
Magnetic Energy .....	7
Magnetic Circuits .....	7
Electrical Properties of Magnetic Circuits .....	8
Soft Magnetic Materials .....	8
Core Loss .....	8
Energy Storage vs. Energy Transfer .....	9

### Applications with Descriptions

Description of Applications .....	9
Types of Materials .....	11
Soft Ferrite .....	11
Scrapless Laminates .....	11
Powdered Iron .....	11
MPP .....	12
HI-FLUX™ .....	13
SUPER-MSS™ (Sendust) .....	14
Toroidal Tape Cores.....	14
Cut Tape Cores .....	17
Bobbin Tape Wound Cores.....	18
Silectron Toroids.....	19
Silectron C and E Cores.....	19
Distributed Gap Cores.....	19

### Selection of Materials by Application

Frequency and Application.....	19
Low-frequency Applications (Power Conversion).....	19
High-Frequency Applications.....	20
Major Industry Typical Applications .....	20

### Appendix

Recommended Application Tables.....	22
-------------------------------------	----

## Introduction

The earth itself has magnetism. Ages ago, seagoing navigators learned how to use this phenomenon to sail their ships accurately from one port to another.

All of us are aware that the earth spins on an axis, the opposite ends of which have been designated as the geographic north and south poles. These geographic poles are near the earth's magnetic poles.

Invisible magnetic lines of force completely surround the earth. Oversimplified (but adequate for this discussion), these lines enter the earth at one pole, pass through the earth, exit at the other pole, and then loop back to the first pole. They are useful not only to the mariner on the high seas but also to the airplane pilot aloft.

Ancient mariners learned that certain substances, known as lodestones, would always point approximately north or south when suspended on a string. If the lodestone was deliberately moved from this position, it would slowly return to its original orientation. This gave evidence of a strange force which man could use.

Long after the mariner's compass became a universally useful navigational instrument, other pioneering scientists observed that a voltage could be measured between the ends of a piece of wire moved across magnetic lines of force. They also learned that, if the ends of a long enough wire were touched together, a tiny spark could be seen when the wire was moved very rapidly. Gradually, as these phenomena were observed by scientists and word of their observations was circulated, the relationship between electricity and magnetism was discovered.

Although they did not understand the causes at first, they eventually developed the idea that something was flowing in the wire. In due course, new words such as voltage, current, resistance, and impedance began to creep into the strange, new jargon of science. Each new discovery added to the previous knowledge and, through such evolution, order developed out of conflicting opinions. That process continues today, although the points of discussion and discovery are now many times more specific in nature than the general concepts developed in the past.

Virtually everyone has an intuitive understanding of simple magnetic devices like the lodestone. However, an individual designing today's sophisticated magnetic products for the commercial market place must have a deeper knowledge and understanding of the subject.

The following training document provides some of the information and understanding needed to use magnetic products successfully. You'll find general information on magnetic theory and specific information on magnetic core types and applications. It requires a modest understanding of electrical circuits and basic principles of electronics, so some preparatory study would be beneficial for anyone without such background.

There are many ways to get up to speed in this subject. The possibilities include a basic electronics course of study or one of the programmed learning packages on the market. For example, the Heath Company offers a variety of electronics educational products.

## Basics of Magnetics

### Energy

Arnold serves industries and individuals deeply involved with conversion and utilization of magnetic energy. Their actual final products can range anywhere from computers to electrical power distribution to automobiles. This manual provides an understanding of the basic phenomenon of magnetics and how Arnold products allow it to be put to practical use.

Any energy form—be it electrical, thermal, chemical, or mechanical—is only of value to us if it can be used in our everyday life. This is called doing work. To do work for us, energy must be converted from one form to another. The products that Arnold manufactures facilitate this conversion and make it efficient enough to be of practical use. It is certainly possible to make permanent magnet (PM) motors with lodestone motor arcs and transformers from cut-up tin cans. But, how efficient would they be, and would they allow the design of the everyday electro-magnetic devices that have become necessities to us?

Understanding the formation and utilization of energy is very important.

### Units of Measurement

Before getting too involved in a discussion of magnetics, you should spend some time on one of the most controversial subjects you will encounter: the system of units that information/literature/design documentation should be using. Arnold has traditionally used the **CGS** (centimeter-gram-second) system. Its principal advantages are that the units are nicely "sized" for real-world magnetic materials, and that the permeability of free space is equal to one. (This last point will be defined more clearly later in this document.)

Unfortunately, CGS units receive only passing mention in formal training in electromagnetic theory. The system of choice in academic and scientific communities is the **SI** (System Internationale) system. These units can be more awkward to use, and the permeability of free space is an exponential number. On the other hand, mathematical operations are much simpler when going from energy to power to flux density, etc.

### Simple Magnetic Theory

Fundamental to **all** magnetic theory is the concept that a magnetic field is produced when a current

passes through a conductor. The direction and intensity of this magnetic field is a function of the direction and amplitude of the current.

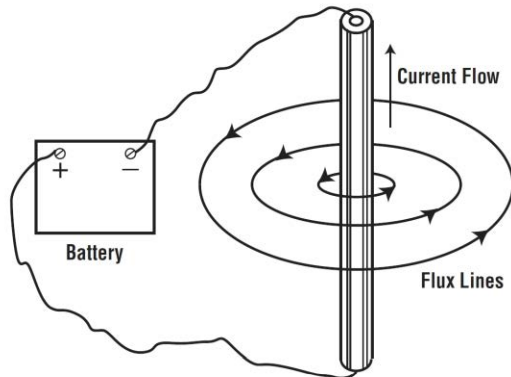

Fig. 1

The simple circuit shown in Figure 1 depicts how electrical energy is converted to magnetic energy. A current source, in this case a battery, is attached to a length of conducting wire. Because the electrical circuit is closed, current flows. This current is called the excitation current and, when used with a certain coil geometry, results in what is referred to as the **Magnetizing Force**, or **MMF per unit length**, or the **H** of the coil. The unit of the measure is **Oersted** in CGS

MMF (magneto-motive force) are **Gilbert** in CGS and **Ampere-turns** (amp•turns) in SI units.

$$1 \text{ amp-turn per meter} = 0.012566 \text{ oersted}$$

The flow of current creates a “force field” that is concentric with the conductor. This field was arbitrarily called a magnetic field by 19th century researchers, and a measure of its magnitude was called Flux, or lines of flux, or B. In other words, some amount of amps of current creates some number of lines of flux. The resulting magnetic field is a pool of potential energy. The unit of flux is the Weber or the Volt-second in the SI system, and the Maxwell in CGS.

$$1 \text{ weber} = 1 \text{ volt-second}$$

$$1 \text{ weber} = 10^8 \text{ maxwells}$$

From this simple beginning, scientists manipulated the magnetic phenomenon to perform work. The single loop of wire was made into a multiple-turn coil (see Figure 2), proportionately increasing the number of lines of flux produced by the same amount of current (same number of amps). One of the few ways early researchers had to measure the amount of flux produced by the current-carrying coil was to observe the amount of attractive force a coil exhibited when near a ferromagnetic material (e.g. steel). It was only a matter of time before someone came upon the idea of putting an iron “core” inside the coil (see Figure 3) and, naturally enough, the amount of force produced increased drastically over previous experiments.

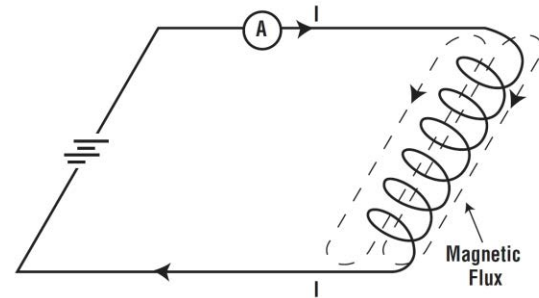

Fig. 2 Schematic representation of magnetic flux resulting from current flow in a coil.

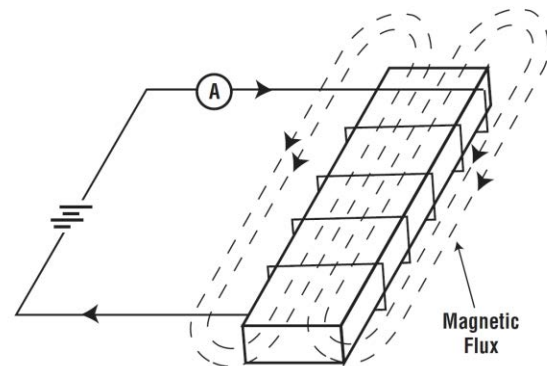

Fig. 3 Schematic representation of increased magnetic flux with a ferromagnetic core.

Two important concepts began to evolve from this research. The first is the presence of an iron “core” increased the concentration of lines of flux within the coil of wire. This established the concept of flux density, or number of lines of flux per unit of cross-sectional area. Flux from a coil or magnet is also referred to as induction. The unit of measure of flux density is **Gauss** in CGS units and **Tesla** in SI units. Occasionally an engineer will use “lines per square centimeter” as a unit of induction, and while correct, it is no longer common.

$$1 \text{ line of flux} = 1 \text{ maxwell}$$

$$1 \text{ gauss} = 1 \text{ maxwell per cm}^2$$

$$1 \text{ tesla} = 10,000 \text{ gauss}$$

$$1 \text{ tesla} = 1 \text{ weber per meter}^2$$

Flux density is one of the components used to determine the amount of magnetic energy stored in a given geometry. The other component is the MMF, described previously.

Another important concept that became apparent was in a situation where a ferromagnetic material was inserted into a coil (see Figure 3), the flux (or flux density) was actually the result of two constituents—one being the contribution of the coil itself, the other the contribution of the iron core. These two parts are additive, and the total flux is the sum of the two.

$$FLUX_{\text{magnet}} + FLUX_{\text{coil}} = FLUX_{\text{total}}$$

The significance of this is best demonstrated by the use of normal and intrinsic demagnetization curves in permanent magnet product literature. The intrinsic curve is representative of the magnet's contribution, and the normal curve is the magnet plus the externally applied (coil) magnetic field. There will be further discussion of this later in this document.

## Permeability

Not all magnetic materials respond equally to an applied magnetic field. Different materials exhibit different flux densities when subjected to the same magnetization levels. To account for this, scientists developed a term to describe the mathematical ratio of flux density to magnetizing force. This ratio, called **Permeability**, is a measure of the magnetic sensitivity of the material. Permeability is the ratio of B (induction) to H (applied magnetic field).

Every magnetic material has a permeability that is numerically greater than the value of the permeability of free space – which is 1.

Absolute permeability of free space = 1 (CGS units) or  $4\pi \times 10^{-7}$  H/m =  $4\pi \times 10^{-7}$  Wb/(A·m) (SI units)

This means that magnetic materials are more responsive to an applied MMF than the space (air) they occupy. There are also several different definitions for permeability depending where on the hysteresis loop we refer to. Some of these are: initial permeability, incremental permeability, (relative) recoil permeability and maximum permeability. When referring to permanent magnets, we most often speak of recoil permeability. For more detail see the Glossary of Terms for the Magnetics Industry.

The (relative) recoil permeability of some permanent magnets is:

- Hard ferrite ~1.045
- Neo (NdFeB) ~ 1.05
- Samarium-cobalt is between 1.03 and 1.08
- Alnico is 1.5 to 7 depending upon grade

With soft magnetic materials we refer to the maximum permeability with some typical values being:

- MPP = 14 to 350 depending on powder loading
- Powdered iron = 8 - 75
- Silectron = up to 30,000
- Supermalloy = up to 300,000

Unfortunately, the permeability of magnetic materials is not constant especially for soft magnetic materials. Permeabilities will change over a several-decade range as the excitation (applied field) level is varied. Real-world materials are also affected by their environment such as temperature and mechanical shock which can have a profound effect on the observed value of permeability.

## Saturation

Although magnetic materials are more susceptible to excitation than air, they have the drawback of limited flux carrying capacity. As the applied excitation becomes greater, the material reaches a point where its permeability approaches the permeability of free space and it cannot carry any more magnetic energy. This point is referred to as **Saturation** and is characterized by the material's **Saturation Flux Density** (saturation magnetization,  $M_S$ , or saturation polarization,  $J_S$ ).

Saturation magnetization is related to a permanent magnet's  $B_r$  (residual induction) and is usually only of interest in that the  $M_S$  must be higher than  $B_r$ . Thus a high  $B_r$ , a strong magnet, requires a high  $M_S$ . For soft magnetic materials on which we depend for carrying flux in magnetic circuits, the  $M_S$  is a measure of that flux carrying capability. However, soft magnetic materials also benefit from having low values of coercivity ( $H_{CB}$ ). A good soft magnetic material usually has both a low  $H_{CB}$ , a large maximum permeability (ease of magnetization) and a high  $M_S$  (saturation magnetization). When a soft magnetic material is specified to have a minimum value of saturation flux density, it is also necessary to specify at what excitation level (at what applied field) this magnetization is to be measured.

## BH Loop

In order to differentiate the properties of specific materials, a measurement technique was devised that shows all the characteristics described above. This is the hysteresisgram, or as it is more commonly called, the **Hysteresis Loop** or **BH Loop**. Since it is of such basic importance to magnetic designers, some explanation of its features will be given.

The BH loop is obtained by exciting the magnetic material sample with a controlled, and varied, external magnetic field and simultaneously recording the resulting magnetization induced in the sample. Generally the format is to excite the sample to saturation in the positive (+H, applied field) direction and then to reverse the applied field direction to excite in the opposite (negative) direction. The final step is to reverse direction again and return to either zero external field or to complete the loop by applying an adequately large positive field to again saturate the magnet in the original direction.

The sample may or may not be driven to saturation during the test sequence. This point is of particular significance in permanent magnets, where the full potential of a material can only be realized if it is completely saturated when magnetized for measurement or use. For rare earth magnets it is usually required to pulse magnetize to saturation prior to attempting measurement. Devices that measure magnetic fields are called magnetometers. The type of magnetometer used to measure the hysteresis loop is called a hysteresisgraph.

Figure 4 shows an example BH or hysteresis loop. Induction, B, is displayed on the vertical axis and applied

magnetizing force,  $H$ , is on the horizontal axis. Positive and negative values of both parameters are utilized. One variation of the BH loop is the demagnetization curve commonly used to display the properties of permanent magnet materials. The “demag” curve only represents the second quadrant of the full BH loop. The material has been magnetized and then a gradual demagnetizing field is applied in an attempt to demagnetize the sample, thus the term “demag” curve.

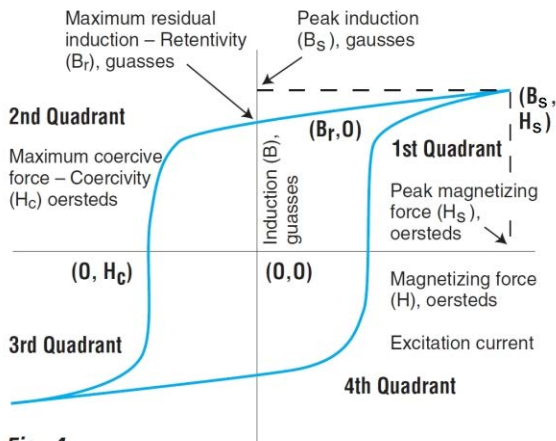

Fig. 4

For thorough analysis, the magnetic material sample should start out unmagnetized. This would be the axis point  $(0,0)$  on the BH loop in Figure 4. At that point the excitation current is zero and the sample contains no flux. As excitation is increased slowly in the positive direction, flux builds up in the material, also in the positive direction. Generally, the excitation is increased until saturation occurs; but, since this is not always the case, we will assume in this discussion that the material is not saturated. (The occurrence of saturation does not change the following test sequence.) This point of maximum excitation is signified on Figure 4 by  $(+B_m, +H_m)$ , where  $+B_m$  is the maximum flux density observed and  $+H_m$  is the maximum MMF applied. These points are alternatively referred to as  $B_s$  and  $H_s$  where “s” stands for saturation. Current then is slowly decreased to zero, to the point on the curve labeled  $(+B_r, 0)$ . But, as indicated in Figure 4, the flux does not return-to-zero. Instead flux density assumes what is called the residual induction of the sample. The symbol for residual induction is  $B_r$ .

One of the distinguishing characteristics of real world magnetic materials is that they have “memory” of their previous excitation condition. This results in a “lag” in the response of the material when excitation is varied. The residual flux is a manifestation of this phenomenon. (All magnetic materials exhibit residual flux values.) This lag is referred to as **Hysteresis**, from which the name hysteresisgram or hysteresis loop is taken.

When the excitation is increased in the negative direction a demagnetizing force is applied against the sample’s residual induction. Eventually the magnetic

energy, is “neutralized by the applied field and the flux density returns to zero. This is point  $(0, -H_c)$ . The amount of negative MMF required to reduce induction in a material from  $B_r$  to zero is called the (normal) **Coercivity** of the sample material. The coercive force is designated by  $H_c$ . The unit for coercivity is either oersted (Oe) or amp-turn per meter (A/m).

This parameter,  $H_c$ , differentiates “hard,” or permanent, magnetic materials from “soft” materials. Soft magnetic materials are quite easily magnetized and demagnetized. Hard magnetic materials are quite difficult to magnetize and demagnetize - they are better able to retain the magnetic energy stored in them. In either case, unless something occurs to demagnetize the material, magnetic energy will be stored in them almost indefinitely.

The remainder of the BH loop is simply a mirror image of the first two quadrants. The sample is driven to  $(-B_m, -H_m)$ , then  $(-B_r, 0)$  then  $(0, +H_c)$  and finally back to  $(+B_m, +H_m)$ .

As mentioned earlier, the flux in the “air space” within the exciting coil does contribute to the total, or normal, flux observed or measured in the BH loop. Some hysteresisgraphs, as the instruments are called, are equipped to calculate and display the intrinsic BH loop, the loop representing only the induction of the material. Both the normal and intrinsic demagnetization curves are provided for high-coercivity materials (see Figure 5). For intrinsic BH loops, an additional “i” subscript is added to all the defining parameters. In other words,  $H_{ci}$  is the intrinsic coercivity of the sample, whereas  $H_c$  is the normal coercivity. Both normal and intrinsic demagnetization curves are of significance to the PM circuit designer.

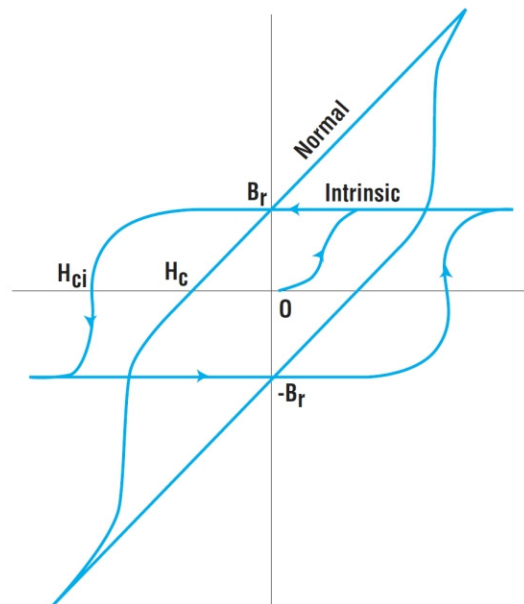

Fig. 5

## Magnetic Energy

The intent and purpose of magnetic materials is to facilitate the conversion, storage and utilization of magnetic energy. By definition, magnetic energy is the product of the induction in the magnet and the magnetizing force it took to excite the material to that flux level.

$$\text{Energy} = B \times H$$

The unit of energy in the SI system is the Joule, in the CGS system it is the **Erg**. In permanent magnet design a special energy density, or energy product, is also used to indicate stored energy. The CGS unit of energy product is the **Gauss-Oersted** (or mega-Gauss-Oersted, MGOe). The SI unit is the **Joule per cubic meter** (or kilo-Joule per cubic meter,  $\text{kJ/m}^3$ ).

$$1 \text{ joule} = 10^7 \text{ ergs}$$

$$1 \text{ joule per meter}^3 = 125.63 \text{ gauss-oersted}$$

$$1 \text{ MGOe} = 7.958 \text{ kJ/m}^3$$

Soft magnetic materials, including core products, have the ability to store magnetic energy that has been converted from electrical energy; but it is normally short-term in nature because of the ease with which these materials are magnetized and demagnetized. This is desirable in electronic and electrical circuits because it allows magnetic energy to be converted easily back into electrical energy for reintroduction into the electrical circuit.

Hard magnetic materials (permanent magnets, PMs) are comparatively difficult to magnetize and demagnetize, so the energy consumed in doing so is large. The portion of the BH loop that shows a permanent magnet's energy storage is the demagnetization portion of the normal curve from  $(+Br, 0)$  to  $(0, -H_c)$ .

If hard magnetic materials dissipated their stored energy back into the magnetizing electrical circuit quickly, as do soft materials, they would be of no value to us. Instead, they use this energy to establish a magnetic field which does work by inter-acting with, for instance, the stator current in a PM motor. Presumably, unless something causes it to become demagnetized, the permanent magnet will maintain this external field indefinitely. One of the common misconceptions is that, somehow, the energy stored in the magnet is being consumed as the motor is operated. This is not true. Think of the magnet as acting like a spring, alternately storing and releasing potential energy as it interacts with other magnetic fields in the application.

## Magnetic Circuits

It is quite convenient to draw an analogy between the more common electrical circuit and something called a **Magnetic Circuit**. A magnetic circuit is a schematic of the magnetic flux path where the MMF sources (PMs and electromagnets) and MMF drops (areas with low permeability) are represented. To complete the analogy, "resistances" are against the applied MMF instead of the

applied current, as is the case in the electrical circuit (see Figure 6).

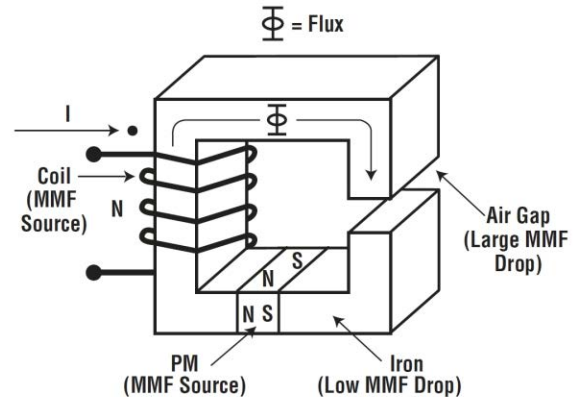

Fig. 6 Typical Magnetic Circuit

To facilitate the analysis of magnetic devices, the concept of **Reluctance** was introduced. This is the magnetic circuit "resistance" referred to above. This mathematical tool not only considers the permeability of that section of the magnetic circuit, but also its dimensions and shape.

The path that the lines of flux will take in a given geometry is analogous to current in an electrical circuit. Electrical current takes the path of least resistance. Magnetic flux takes the path of least reluctance. Reluctance is inversely proportional to permeability.

Minimum reluctance is realized when the permeability of the magnetic materials are high, when the **Air Gap** in the magnetic path is reduced, and the configuration tends toward the materials forming a closed loop (see Figure 7). In a PM circuit, the effect of reluctance is to diminish available flux in the air gap. Higher operating flux densities can be realized if the air gap (reluctance) in the PM circuit is designed with minimum reluctance.

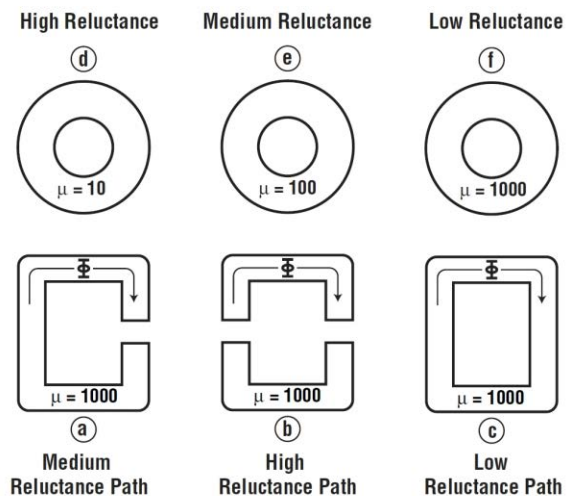
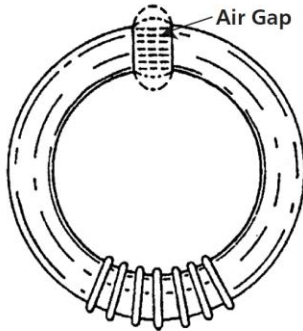

Fig. 7

An air gap is introduced into magnetic circuits in two ways: a **Discrete** air gap and a **Distributed** air gap (see Figures 8 and 9, respectively). Discrete air gaps are significant in both PM and soft magnetic circuits while a distributed air gap is applicable to powder core products.

A discrete air gap, as used in a gapped C-Core or in a PM motor, is best described by a situation where a limited number of comparatively large air gaps are introduced into a basically high-permeability material that is part of the path of the magnetic circuit.



**Fig. 8** Cutting a small section out of an iron ring to make an air gap increases the total reluctance and therefore reduces the total flux.

A distributed air gap refers to a very large number of small gaps distributed throughout a core. Examples of distributed air gap products are Molybdenum Permalloy Powder (MPP), ferrite and powdered iron cores. Because it minimizes second-order effects such as leakage and fringing flux, distributed air gaps permit much larger effective air gaps in the magnetic path.

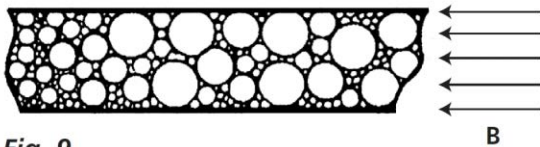

**Fig. 9**

There are other ways to obtain an air gap. One common method in a C-core is where in the normal manufacturing process, the binder impregnation lowers permeability of the material by creating air gaps between lamination layers. Additionally, dynamic effects such as core loss tend to create an effective air gap by reducing the net permeability of the material.

## Electrical Properties of the Magnetic Circuit

Devices made with magnetic materials are often used to interact with fields from electrical current to perform useful work. This is almost always true of soft magnetic products and quite often true of permanent magnets

(e.g., in a PM motor). Whenever the device is connected to an electrical circuit that provides current, certain electrical properties will be exhibited in that circuit. One of the most significant is **Inductance**.

Inductance, along with resistance and capacitance, are three basic characteristics of any electrical circuit. Inductance determines the electrical **Impedance** that the device presents in the electrical circuit. Impedance, in an AC circuit, is a combination of resistance and reactance. Impedance, in turn, dictates the electrical current that will flow. The unit of inductance in both SI and CGS systems is the **Henry**. The unit of resistance in both systems is the **Ohm**.

Mathematically, inductance is inversely proportional to the reluctance of the magnetic circuit. Thus a core with a large air gap (a high-reluctance magnetic circuit) will provide very little impedance to the electrical circuit. Likewise, a PM motor designed with a very large clearance between the rotor and the arc magnet will tend to provide less impedance to the circuit supplying the electrical power.

When a magnetic material saturates, relative permeability decreases and reluctance increases rapidly. Consequently, the impedance of that device tends toward zero and it begins to “disappear” from the electrical circuit.

## Soft Magnetic Materials

Soft magnetic core products include Molybdenum Permalloy Powder (MPP), HI-FLUX (50:50 Ni-Fe), Sendust (Si-Fe), ferrite and iron powder cores. In addition, a wide variety of tape wound products are available including 3% Si-Fe, amorphous and nano-crystalline alloys. Discussion herein will be restricted to core products.

## Core Loss

Core loss is extremely important in soft magnetics. Core loss represents inefficiency, an energy loss, so it is highly disdained by the designer. In many instances, core loss will render a particular material unsuitable for use in an application. The most glaring example would be the high frequency power-conversion transformer industry, which is dominated by low-loss soft ferrites. **E x c e p t i o n s** include flyback transformers operated in a lower range of switching frequency and high frequency power conversion inductors. The unit of core loss in both SI and CGS systems is the **Watt** and it is often expressed as watt per pound (cgs) or watt per kilogram (SI).

$$1 \text{ watt} = 1 \text{ joule per second}$$

Core loss is the result of two major components: **Hysteresis Loss** and **Eddy Current Loss**. Hysteresis loss results from the fact that not all energy required to magnetize a material is recoverable when it is demagnetized. The wider and taller the hysteresis loop, the more hysteresis loss a material has. Hysteresis loss is



proportional to the area within the normal hysteresis loop. The area of the loop is determined by  $H_c$ ,  $B_s$  (saturation induction) and the shape of the loop.

Eddy current loss is the result of small circulating currents (eddy currents, not unlike eddy currents produced in the wake of a boat) that are induced in the magnetic material when the flux carried by the magnetic material changes in intensity and direction (see Figure 10). The amplitude of these small currents is dependent on the magnitude of the applied magnetic field and on the **Electrical Resistivity** of the material. As a point of comparison, soft ferrites, while having moderately large hysteresis loss, have very high resistivities and resulting low eddy current loss. This is the reason they are often the material of choice for high-frequency applications.

## Energy Storage vs. Energy Transfer

Energy storage is a fundamental concept in magnetic theory. In soft magnetic materials this is exploited to introduce “time delay” into electrical currents via the mechanism of inductance. For instance, this time delay can be used to differentiate between frequencies or filter out unwanted frequencies in the excitation current.

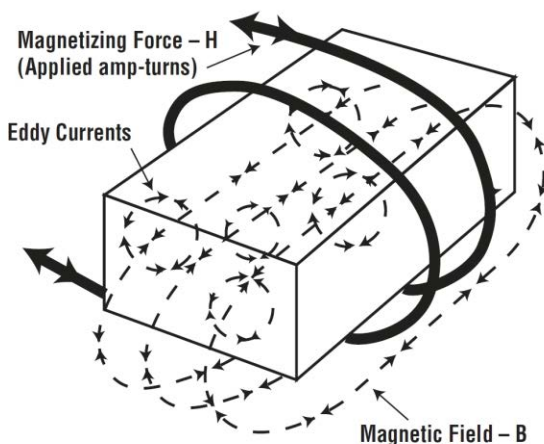

Fig. 10 Energy Loss in form of heat

The **Inductor** or the **Choke** utilizes the concept of storing electrical energy in the form of magnetic energy. The flux build-up in the core is proportional to the applied current and to the permeability of the soft magnetic core material. The magnetic energy is converted back into electrical energy as soon as the exciting current is removed.

Energy stored in a magnetic circuit (or core) is proportional to the applied excitation current multiplied by the resulting flux (induction). Consequently, to increase the amount of energy stored in a given core (assuming that the basic dimensions don't change), there are only two possible alternatives: increase the induced flux or increase the applied coil amp-turns. Since all materials have an inherent and unchangeable saturation flux that

limits the obtainable flux density, once this maximum is reached, the only other option is to increase the applied current to force the core into saturation: in other words, to “desensitize” the core to the magnetizing current. This is quite easy to accomplish simply by mechanically lowering the effective permeability (increasing the reluctance) of the device. This is almost always done by introducing an air gap into the magnetic circuit.

**Energy Transfer** is a special case of energy storage that is somewhat more difficult to understand than energy storage, which is basic to all magnetic devices.

Energy transfer in a magnetic device is most typically represented by a two-winding **Transformer**, where excitation current flows in one winding, the primary, and an induced voltage appears in the other winding, the secondary. At first look, one might be tempted to say that no energy storage is taking place in a typical transformer. This is not the case. In fact, two energy conversion/storage mechanisms are taking place.

The first is the familiar “time delay” energy storage already described as a result of inductance. This is generally undesirable in a transformer because it detracts from the efficiency of the transfer. Usually every attempt is made to minimize exciting energy. The user wants maximum permeability in the core of a transformer, so air gaps—either real or apparent—are minimized.

The desirable conversion/storage mechanism occurs where magnetic energy stored in the core is almost instantaneously transferred to the secondary winding and the electrical load attached to it. The core never really “sees” this magnetic energy, and the magnetic circuit does not have to support any flux created by the conversion. The energy consumption of the load attached to the secondary winding is said to be “reflected” into the primary circuit.

## Descriptions of Applications

Devices using soft magnetic materials are used extensively throughout the electronics and power-distribution industries. Selecting the right material and core type for a given application can be difficult and confusing. In this discussion, we will adhere to the differentiation between inductors and transformers and expand upon variations in each of these groups.

**Power Transformers.** The primary purpose of a power transformer is to convert AC energy from one combination of voltage and current to another and simultaneously provide electrical isolation between the primary and the secondary windings. Power transformers have two or more separate windings. The ratio of the number of turns in the primary winding to the number of turns in the secondary winding determines whether the voltage is “stepped up” or “stepped down.” Disregarding winding and core losses, total watts (power) input to the primary of the transformer is equal to the watts output from the secondary

winding. Power transformers will often have more than one secondary winding and the output power is apportioned according to the turns in the individual windings.

The majority of power transformers fall into two categories: Low-Frequency power transformers used at frequencies less than 1000 Hertz and High-Frequency power transformers used at frequencies above 1000 Hertz. These definitions are not universal, and 1000 Hz was selected as a semi-arbitrary reference point. Variations of power transformers include:

- Wide (frequency) band transformers.
- Impedance matching transformers.
- Pulse transformers.

**RF Transformers.** RF (radio frequency) transformers operate at low-to-moderate power levels above 500 KHz. These devices are the same as a power transformer except that their primary application is to couple AC signals from an output stage of an RF amplifier to the input of the next stage while electrically decoupling the DC component of the signal. RF transformers are used extensively when coupling the high-potential plate output of an amplifier to the input of the next stage.

Other RF transformers include Baluns transformers, which are used for impedance matching of circuits.

**Precision Transformers.** Precision transformers are special devices used in “sensing” and instrumentation applications.

One very common type of precision transformer is the **Current Transformer**, or CT. CTs have one turn of high-current-carrying wire for the primary. The secondary high-turn-count winding produces a low-level current proportional to the turns-ratio of the windings and to the current in the primary. CTs are used extensively in both the electronics/power-conversion and the power-distribution industries.

Another precision transformer is called the **Flux Gate Magnetometer**. This transformer is used to detect very low-level magnetic fields or very small changes in a magnetic field. These devices have applications in electronic compasses as well as navigation systems. Since flux gate magnetometers can detect the distortion in the earth’s magnetic field caused by the presence of armored vehicles and ships, they are used as triggering devices for mines and other types of armament.

A third type of precision transformer is the **Hall Effect Transducer**, which has a gap in the magnetic path of the core in which a Hall effect device is placed. The flux generated in the core by the current in the winding (often just one turn) causes the Hall effect device to produce an output voltage proportional to the flux level.

**Saturable reactors** are used for voltage and current control at high power levels. A special core winding is placed on the saturable reactor, and DC current that passes through this winding will drive the device into

and out of magnetic saturation. This, in effect, changes the device’s flux transfer ratio, and subsequently the output power of the device is controlled. Large electric industrial furnaces, welders, and high-power voltage regulators commonly use saturable reactors as the controllable source of power.

A variation of the saturable reactor is called **MAG AMP**, which operates on the same control-winding concept as the saturable reactor. Mag amps are used as variable series impedance in square wave and pulse wave applications, being driven into and out of saturation within a single cycle. One popular application for a mag amp is as a post regulation technique on the output stage of **Switchmode Power Supplies**.

To work effectively, saturable reactors and mag amps require magnetic material with a very square loop to allow for a sharp transition into and out of saturation.

**Pure Inductors** are used at all frequencies to provide an electronic circuit with inductive reactance. Such a circuit may be in communications equipment, where the combination of inductive and capacitive reactance is used to tune a stable frequency in an oscillator stage or to provide selective filtering in a band pass filter. Larger pure inductors, called **loading coils**, offset the effects of capacitance built up in long lengths of conductor such as antennae or telephone lines. Pure inductors can be either fixed or variable, depending on their application.

**EMI Filters:** Electromagnetic interference (EMI) is produced by a multitude of electronic and electrical devices including motors, light dimmers, digital computing devices, switchmode power supplies, and motor speed controls. EMI can be radiated through the air or transmitted through device wired conductors. It can interfere with communications, such as radio and television signals, and can affect computer devices that use low level high-frequency transmissions.

EMI filters can be used in conjunction with a capacitor to form a highly efficient and selective band pass or band stop filter to impede unwanted (EM) noise. EMI filters eliminate noise by converting it to heat (core loss). These lossy filters work well when the noise-component frequency is much higher than the frequency of the desired signal.

An often used type of EMI filter is the **Common Mode Filter**, which is wound with both conductors of the power source in such a way that noise common to both conductors is filtered. The desired signal passes through the common mode filter unimpeded.

**Energy Storage Inductors** release the energy stored in them when the voltage across the device is switched. These inductors typically are found, for instance, in the output stage of switchmode power supplies. In this application, the energy storage filter (in conjunction with a filter capacitor) smoothes the ripple current that is superimposed on the DC output of the converter. This filter will also provide some EMI filtering of the

inherent noise caused by the high-frequency switching. These devices operate with large DC current and must maintain a reasonably constant inductance (or core permeability) at high flux levels.

The **Flyback Transformer** is a special type of energy storage device that performs both energy transfer and energy storage functions. It is used in low cost, high-frequency power conversion. The type of core used in this device must have moderately high permeability for good flux transfer and, at the same time, high saturation flux density for better energy storage capacity.

## Types of Materials and Available Shapes of Cores

**Soft Ferrite.** Soft ferrites are derived from iron oxide obtained from the cleaning of steel (pickle liquor) or mined from the earth. Metals such as nickel, manganese and zinc are added to the iron oxide. Ferrite material is then pressed and fired to form a crystalline structure that gives ferrite cores their soft magnetic properties. Subsequent grinding or coating operations may take place before the core is used.

**Manganese-Zinc** soft ferrites have high permeability and low eddy current losses; **Nickel-Zinc** ferrites have lower permeabilities with very low eddy current losses. A variety of materials spans the frequency range from 10 KHz to 1 GHz and up. Soft ferrites have low saturation flux densities, in the range of 2500 to 4000 gauss, but are available in shapes that can be readily gapped to handle more MMF at the sacrifice of permeability. Because of their very low core loss at high frequency, ferrites are used extensively in switchmode power supplies as power transformers, filter inductors, current transformers, and mag amps.

Ferrites are available in a wide variety of shapes and sizes with volumes up to about 500 cm. Some other common applications for ferrites are rod antennas, common mode filters, RF transformers, and pure inductors.

Ferrites were plagued for many years by their extremely wide physical and magnetic tolerances. Additionally, ferrites are hindered by rather large temperature dependence. Extensive research and development has improved, but not eliminated, all of the soft ferrite shortcomings. Because of their widespread manufacture, low cost, and readily available technical information, soft ferrites are the most widely used magnetic material at **High-Frequency**.

## Scrapless Laminations and Shearings

Scrapless laminations are usually in the shape of E-E's, U-I's, or E-I's. They are punched from a continuous roll of thin-gauge magnetic material, most commonly silicon-iron, either non-oriented or oriented types. Nickel-iron

or cobalt-iron thin-gauge materials are also available for use as laminations.

Because of the way they are manufactured, tooling costs are high (the die). For low-quantity requirements, laser cutting is used. Scrapless laminations are taken, one piece at a time, and "stacked" up into a core assembled around the coil. Special stacking machinery is available to facilitate the construction of this type of device. The advantage of scrapless laminations is that, in high-volume applications, it is the least expensive choice for low-frequency, high-permeability requirements.

Shearings are thin-gauge strip that is "sheared" to length. Sometimes the shearing is done with a miter, and sometimes "bolt holes" are stamped into each piece. Material is virtually always silicon iron. Shearings are "laid up" into E-I and U-I shapes to form cores for large transformers. The advantage of this type of construction is that it allows fabrication of very large transformers and inductors. The cores in large substation transformers can easily weigh many thousands of pounds.

Silicon-iron scrapless laminations and shearings are the most widely used soft magnetic cores for 60 Hz applications.

## Powdered Iron

Powdered iron cores are made from 99+% pure iron in the form of very fine powder particles. There are many different grades of powdered iron material, ranging from cheap-and-dirty sponge iron to the fairly expensive carbonyl powders. These materials are purchased in powder form, and the particles are mixed with insulating and binding materials and pressed to finished shape at moderately high pressures (2 to 8 metric tons per cm<sup>2</sup>). Hard tooling (punch and die) is required.

Coating/binding agents are cured after the pressing operation, but the cores are not metallurgically annealed. The intent is that the individual particles **not** fuse or electrically short out. Powdered iron cores are not sintered iron parts, a common misconception (see Figure 11).

Because the particles are ideally separated by an air gap (occupied by insulating and bonding material), a distributed air gap is created. Although the raw material used, iron, has a moderately high permeability, the finished powdered iron core has a maximum effective permeability of about 90.

Powdered iron cores can be divided into three permeability categories: high, medium, and low.

**High permeability** cores, 60 to 90, are used primarily for EMI and energy storage filters. Effective frequency range is up to about 75 KHz.

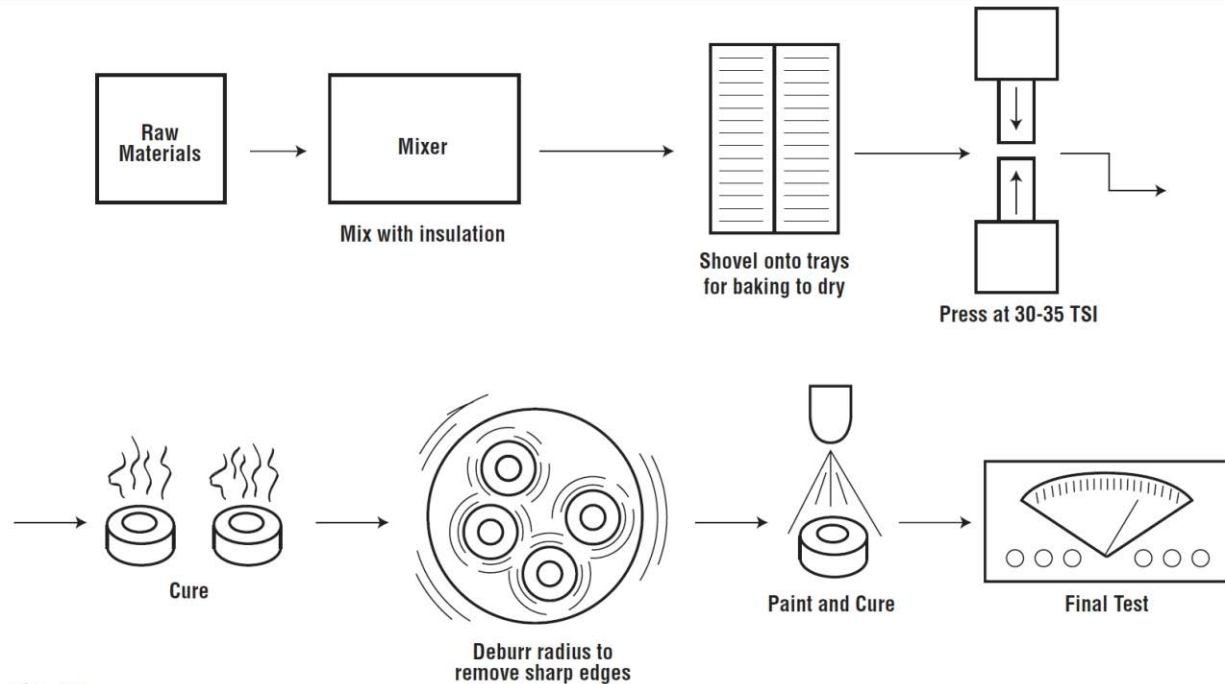

Fig. 11

**Medium-permeability** powdered iron cores, with permeabilities from 20 to 50, are used as RF transformers, pure inductors, and energy storage inductors. These materials are used at frequencies from 50 KHz to 2 MHz. They can handle higher flux densities and higher power levels without saturating than can their ferrite counterparts. This powdered iron family will become more attractive to switchmode power supply manufacturers as nominal frequencies of operation fall into the range of 250 KHz to 1 MHz.

**Low-permeability** powdered iron cores, with permeabilities of 7 to 20, are used almost exclusively in the RF range. Typical applications are RF transformers and pure inductors in the frequency range from 2 MHz to 500 MHz. Some radar applications use powdered iron cores at frequencies in excess of 1 GHz. Good flux characteristics combined with low loss and good temperature stability make this type of core material popular for applications in the communications industry.

The versatility of powdered iron pressing techniques allows for many varieties of sizes and shapes limited only to the extent of today's metal powder pressing technology. Most powdered iron materials, after manufacture, can be ground and lightly machined for special shapes and prototypes.

Because of inexpensive raw materials (iron), powdered iron cores are used in low-cost applications, such as consumer products.

**Advantages** of powdered iron are:

1. low-cost energy storage
2. high energy storage per unit volume
3. temperature stable
4. relatively low-cost tooling
5. available in a variety of shapes

**Disadvantages** of powdered iron are:

1. limited permeabilities available
2. relatively high core loss
3. permeability varies with AC flux density

Electrical testing for quality control purposes is primarily to determine the effective permeability of the core. Additional testing is occasionally done to determine saturation characteristics (DC bias testing) and core loss properties (Q testing).

## MPP

Another type of powder core is the **MPP core**, pressed from powder made of 81% nickel, 2 to 4% molybdenum and balance iron. Raw materials are melted and cast into billets, which are hot-rolled into a brittle sheet. This sheet is then milled into powder form. Insulating binders are mixed into the MPP powder before pressing into cores at high pressures of up to 20 tons per  $\text{cm}^2$ . MPP cores are stress-relief annealed after pressing (see Figure 12).

The normal effective permeability range for MPP is 14 through 350. In order to obtain low permeabilities from a material with such an inherently high permeability, a large amount of distributed air gap is

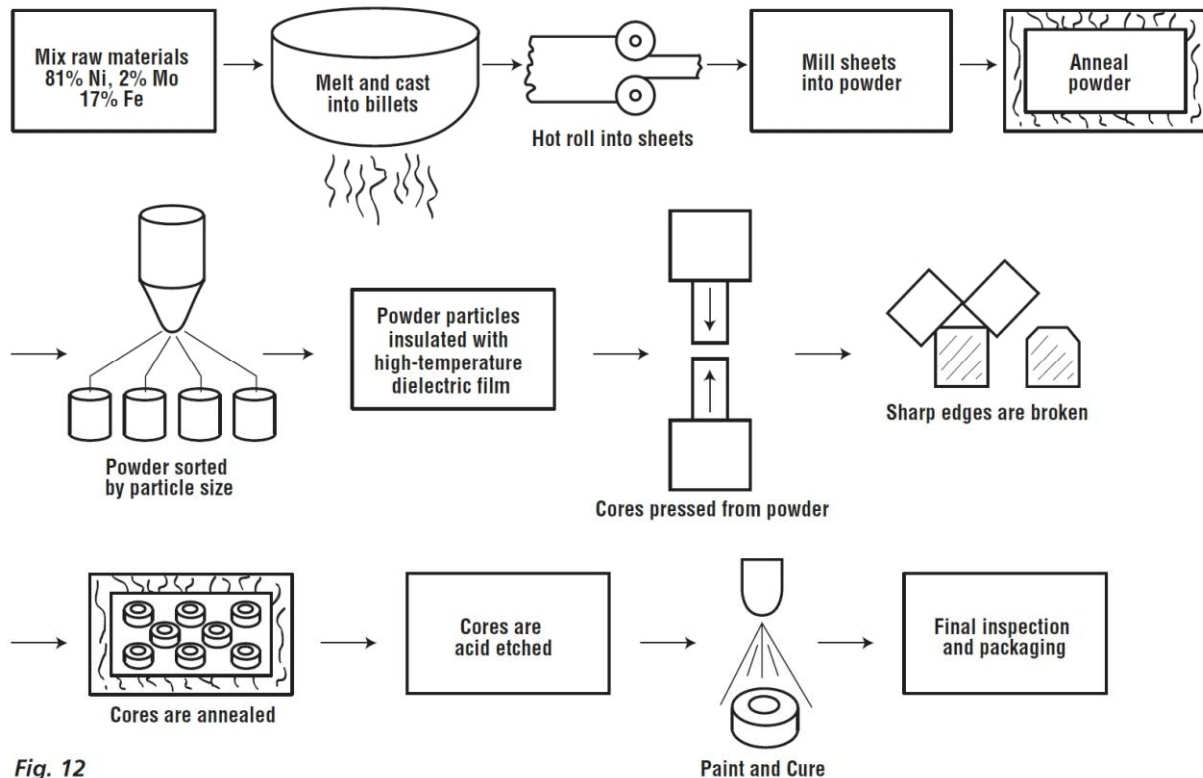

Fig. 12

added. Because of this large amount of air gap and resultant skewing of the hysteresis loop, MPP cores are extremely stable relative to flux density, temperature and DC current. They are almost always used for inductors and other energy storage applications.

MPP cores are normally sold pre-graded to a specific permeability tolerance. This feature makes them ideal for pure inductors, because the precise inductance will be known before winding and the number of turns wound onto the core can be adjusted. MPP cores are also widely used for energy storage inductors due to their low inductance variability when DC bias is applied.

The lower-permeability MPP cores can be used at frequencies that exceed 500 KHz. As the permeability of the core increases, stability tends to decrease. The most popular MPP permeabilities are in the 60 to 173 range, where all the advantages of the MPP product are most apparent.

MPP has the advantage of having constant permeability as the flux density varies up to about 3500 gauss. Above that level, permeability does tend to decrease.

#### Advantages of MPP:

1. permeability is ultra temperature-stable
2. high energy storage per unit volume

3. available graded into small increments of permeability range
4. lowest loss of the powder materials
5. permeability is stable with variations in AC flux density
6. lowest magnetostriction coefficient of the powder core materials

#### Disadvantages of MPP:

1. manufacturing cost is higher than that of powdered iron because of the high-performance nickel/iron/molybdenum alloy and high-temperature ceramic-type insulation.
2. very high pressing pressures limit shapes to toroids only

Testing of MPP cores focusses on the evaluation of core permeability. One additional step is to “grade” the cores into small increments of permeability. Core-loss, saturation, and temperature response testing are also routinely performed.

#### HI-FLUX

HI-FLUX cores are a variation of the standard MPP cores; the composition is 50% nickel and 50% iron. Reduced nickel content results in lower cost. The 50:50 composition is

at a second, slightly lower permeability peak in the composition range of Ni and iron. The manufacturing procedure is nearly identical to that for MPP. HI-FLUX cores are produced with permeabilities of 14 to 160 in diameters up to 132 mm.

HI-FLUX cores are designed to operate up to about 6500 gauss, as opposed to the 3500-gauss limit of standard MPP. There is some sacrifice in stability because less distributed air gap is required to obtain reduced permeabilities. Core loss is also higher than MPP. Still, because of their high flux and power-handling capabilities, HI-FLUX cores are used as energy storage inductors and in flyback transformers in SMPS. They are especially well suited for DC and line frequency noise filter inductors (such as the differential-mode choke in a switched mode power supply). Their high saturation flux-density can be used to advantage because core loss is negligible at the low frequencies of these applications.

#### Advantages of HI-FLUX:

1. temperature stability
2. high energy storage per unit volume
3. available graded into small increments of permeability range
4. higher  $B_{max}$  than MPP
5. permeabilities up to 160 compared to less than 100 for powdered iron

#### Disadvantages of HI-FLUX:

1. higher core loss than MPP
2. manufacturing cost is higher than that of powdered iron because of the high-performance nickel / iron alloy and high-temperature ceramic-type insulation.
3. very high pressing pressures limit shapes to toroids only

Electrical testing is the same as for MPP.

## SUPER-MSS

Sendust, or SUPER-MSS, is another variation of the basic powder core. The material is an iron / silicon / aluminum composition manufactured in a manner similar to MPP and HI-FLUX.

Available permeabilities are 26, 60, 75, 90 and 125. Notable attributes of Sendust are low loss compared to powdered iron, HI-FLUX and MPP, and a very low magnetostriction coefficient relative to powdered iron. Because of the low magnetostriction, it produces very low mechanical noise levels when excitation is applied, which makes it popular in EMI inductors where low-frequency AC is being filtered. Core loss is higher than that of MPP but less than HI-FLUX and substantially lower than that of powdered iron. Like other powder cores, SUPER-MSS is low in permeability and thus well-suited for energy storage inductor applications.

The raw materials are used in Sendust (SUPER-MSS) are less costly than either MPP or HI-FLUX.

#### Advantages of SUPER-MSS are:

1. significantly lower loss compared to powdered iron with little added cost
2. low-cost energy storage
3. high energy storage per unit volume
4. temperature stable
5. low magnetostriction, low noise

#### Disadvantages of SUPER-MSS are:

1. limited permeabilities available compared to MPP
2. higher core loss than MPP
3. available only in toroids

Testing is the same as for MPP and HI-FLUX.

## Toroidal Tape Cores

As the name implies, this type of core is toroidal in shape and is manufactured from "tape" (continuous alloy strip). The tape in this case is thin-gauge iron alloy material that has been slit to a specified width.

Materials used depend on the desired combination of permeability, saturation flux, core loss, and loop squareness. Materials include the following:

- 1) Deltamax (50% Ni / 50% Fe)
- 2) 4750 (47% Ni / 53% Fe)
- 3) 4-79 Mo-Permalloy (80% Ni / 4% Mo / 16% Fe)
- 4) Square Permalloy (80% Ni / 4% Mo / 16% Fe)
- 5) Supermalloy (80% Ni / 4% Mo / 16% Fe)
- 6) Supermendur (49% Co / 2% V / 49% Fe)
- 7) 2V Permendur (49% Co / 2% V / 49% Fe)
- 8) Square loop iron based amorphous Namglass I
- 9) Linear iron based amorphous Namglass II
- 10) Ultra-square loop cobalt based amorphous Namglass III

Manufacturing of tape cores is quite similar, regardless of material. In all cases, an insulating coating is applied to surfaces of the thin-gauge alloy strip to eliminate layer-to-layer shorting, and the strip is wound around an arbor piece (mandrel) which defines the ID of the toroid. The wound core is then stress-relief annealed.

Annealing for some materials takes place with a DC field applied to the core to enhance the magnetic properties. After annealing, the toroid is put into a core "case" with a protective damping medium. Toroidal tape cores are quite strain-sensitive, and the case is necessary to prevent mechanical stresses which would degrade magnetic properties (see Figure 13).

Description of available materials.

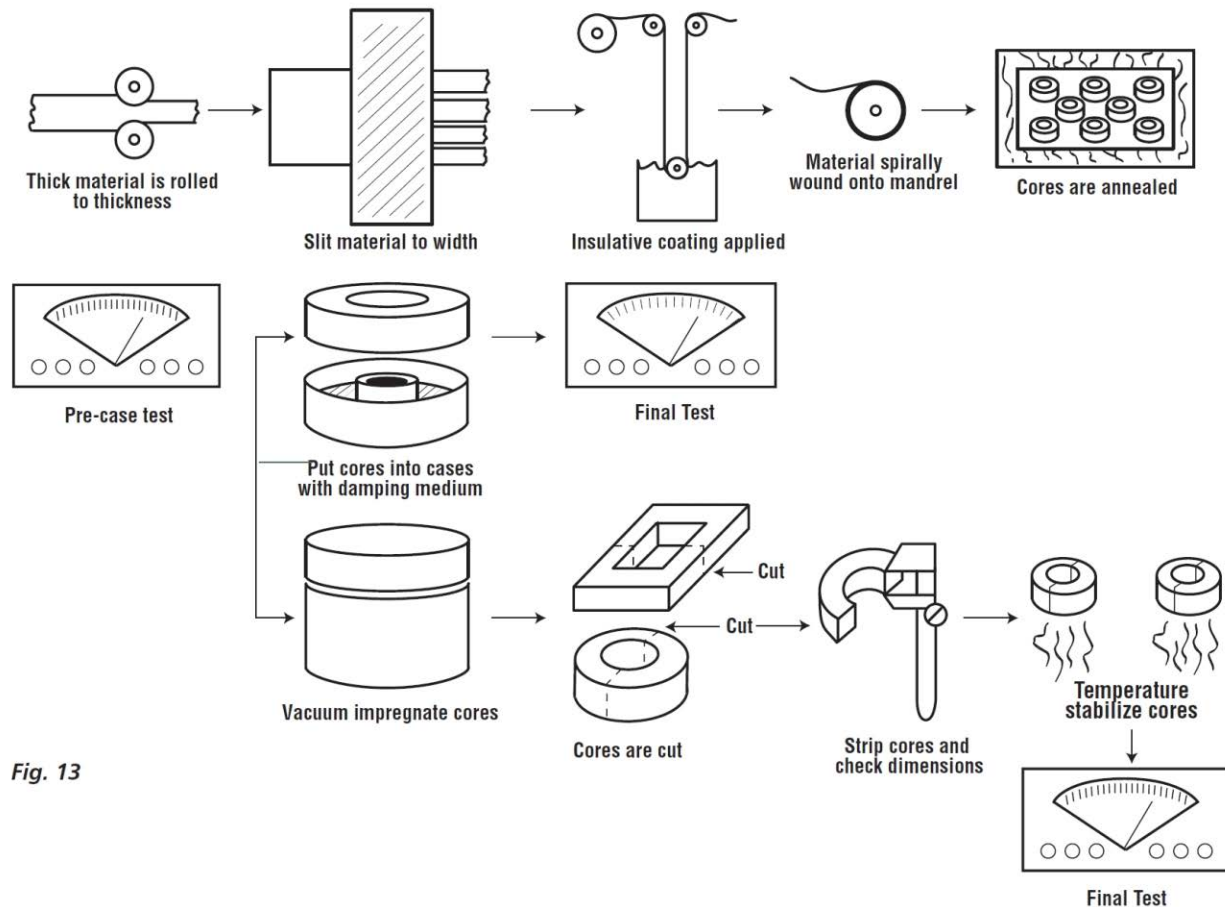

Fig. 13

**Deltamax** is a very square-loop material, meaning that the BR value is very nearly the same as BS. (saturation magnetization) This type of response is desirable in some special-function transformers and inductors such as MAG AMPS and Inverter Transformers.

Raw-material costs are high. Processing Deltamax, as well as all other tape cores, is such that cores are fairly expensive. Applications tend to be military and industrial. Deltamax tape cores are available in 4, 2, 1 and 1/2 mil tape thicknesses.

**Advantages** of Deltamax tape cores are:

1. very square hysteresis loop
2. saturation of about 15000 gauss

**Disadvantages** of Deltamax tape cores are:

1. requires care for maximum properties
2. higher core loss than Permalloy-type material
3. expensive
4. limited frequency response due to core loss

Testing of Deltamax tape cores is almost always with the standard CCFR (constant current / flux reset) test. This method measures the dynamic square loop

response of the core and permits identification of important material parameters.

**4750** is quite similar to Deltamax metallurgically. Instead of having a square hysteresis loop, however, 4750 has a rounded loop with higher maximum permeability than Deltamax.

4750 is also an expensive material, so applications tend to be more specialized. Low-loss **power transformers** and **current transformers** are two frequent applications of 4750. 4750 tape cores are available in 4, 2, and 1 mil tape thicknesses.

**Advantages** of 4750 tape cores are:

1. high permeability
2. saturation of about 15000 gauss

**Disadvantages** of 4750 tape cores are:

1. requires case for maximum properties
2. higher core loss than Permalloy-type material
3. expensive
4. limited frequency response due to core loss

Cores are utilized for their high permeability so testing focuses on that parameter. Initial permeability, measured at low flux densities, is usually specified.

**4-79 Mo-Permalloy**, more commonly known as Permalloy, is a very high permeability, low core-loss material which exhibits a rounded hysteresis loop.

Permalloy is most often used in specialized applications. Current transformers and high-frequency power transformers are typical. 4-79 Permalloy tape cores are available in 4, 2, 1, and 1/2 mil tape thicknesses.

**Advantages** of Permalloy tape cores are:

1. high permeability
2. low core loss
3. low coercivity

**Disadvantages** of Permalloy tape cores are:

1. requires case for maximum properties
2. expensive
3. low  $B_{max}$  (8000 gauss)

Cores are utilized for their high permeability so testing focuses on that parameter. Initial permeability, measured at low flux densities, is usually specified.

**Square Permalloy** is a variation of the basic Permalloy-type material for which anneal has been modified to generate square-loop properties. Although not as square as Deltamax, for instance, it is square enough to operate satisfactorily in mag amps and inverter transformers, especially at frequencies up to about 80 KHz (in 1 mil material).

Applications tend to be military and industrial. Square Permalloy tape cores are available in 4, 2, 1, and 1/2 mil tape thickness.

**Advantages** of Square Permalloy tape cores are:

1. square hysteresis loop
2. low core loss

**Disadvantages** of Square Permalloy tape cores are:

1. requires case for maximum properties
2. expensive
3. limited frequency response due to moderate core loss
4. limited  $B_{max}$  (8000 gauss)

Testing of Square Permalloy tape cores is almost always with the standard CCFR (constant current / flux reset) test. This method measures the dynamic square loop response of the core and permits identification of important material parameters.

**Supermalloy** is another variation of the high-nickel, Permalloy-type alloy. It is state-of-the-art tape core material, as far as highest permeability is concerned. Applications that take advantage of such properties include current transformers.

As with the other tape cores, Supermalloy is most often used in specialized applications. Typical markets would be military, industrial, and research. Supermalloy tape cores are available in 4, 2, 1, and 1/2 mil tape thickness.

**Advantages** of Supermalloy tape core are:

1. highest permeability
2. low core loss
3. very low coercivity

**Disadvantages** of Supermalloy tape cores:

1. require case for protection of properties
2. are expensive
3. have low  $B_{max}$  (8000 gauss)

Cores are utilized for their high permeability so testing focuses on that parameter. Initial permeability, measured at low flux densities, is usually specified.

**Supermendur** is a cobalt-iron alloy for which the anneal has been modified (includes DC stress) for square-loop response. Its most notable characteristic is a  $B_{max}$  of 23 to 24 kilogauss. Although not as square as Deltamax, it is square enough to operate satisfactorily in 400 Hz mag amps and inverter transformers. Because it generally is available only in 4 mil tape thickness, frequencies are limited to 400 Hz and lower.

Applications are almost always military.

**Advantages** of Supermendur tape cores are:

1. square hysteresis loop
2. highest  $B_{max}$

**Disadvantages** of Supermendur tape cores:

1. require case for protection of properties
2. are very expensive
3. limited frequency response due to high core loss
4. 4 mil tape only

Testing of Supermendur toroidal tape cores is almost always with the standard CCFR (constant current / flux reset) test. This method measures the dynamic square loop response of the core and permits identification of important material parameters.

**2V Permendur** is basically the same alloy as Supermendur. Instead of a square hysteresis loop, however, 2V Permendur has a rounded loop with higher maximum permeability than Supermendur.  $B_{max}$  is slightly lower at 21 to 22 kilogauss. 2V Permendur is notable for its very high magnetostriction coefficient.

Applications usually are military or industrial. 2V Permendur tape cores are available in 4 and 2 mil tape thickness.

**Advantages** of 2V Permendur tape cores are:



1. high magnetostriction
2. saturation of about 21000 gauss

**Disadvantages** of 2V Permendur tape cores:

1. requires case for maximum properties
2. higher cores loss than Permalloy-type material
3. very expensive
4. limited frequency of use due to high core loss

Because cores are utilized for their high permeability, testing centers on that parameter. Initial permeability (measured at low flux densities) is usually specified. 2V Permendur also is tested for  $B_{max}$  and occasionally for core loss.

**Namglass I** is one of the amorphous alloys. Raw material is 1 mil thick and slit to the specified width. None of the amorphous materials can be rolled to less than 1 mil. Namglass I is a moderately square-loop material that finds use in **Pulse Transformers**.

Raw material costs are quite high, so markets tend to be in more-specialized industrial areas, such as medical applications.

**Advantages** of Namglass I tape cores are:

1. low magnetostriction
2. saturation of about 14000 gauss
3. high volume resistivity

**Disadvantages** of Namglass I tape cores are:

1. requires case for maximum properties
2. higher core loss than permalloy-type material
3. very expensive
4. limited frequency response due to core loss

Namglass I is tested for  $B_{max}$  and for core loss.

**Namglass II** is another amorphous alloy, similar in composition to Namglass I. Namglass II is a linear permeability material that finds use in **Pulse Transformers** and also in **Common-Mode Inductors**.

**Advantages** of Namglass II tapes cores are:

1. low magnetostriction
2. saturation of about 14000 gauss
3. high volume resistivity
4. low high-frequency core loss

**Disadvantages** of Namglass II tape cores are:

1. requires case for maximum properties
2. very expensive
3. moderate permeability (approx. 5000)

Namglass II is tested for  $B_{max}$ , core loss, and for permeability.

**Namglass III** is another amorphous alloy. Namglass III is an ultra-square-loop material that finds use almost exclusively in high-frequency mag amps. Its metallurgical composition is quite different from the other two amorphous materials in that Namglass III contains cobalt.

Namglass III is finding ever-increasing application in industrial and military power-supply designs.

**Advantages** of Namglass III tape cores are:

1. lowest magnetostriction
2. ultra-square-loop response
3. highest-volume resistivity
4. lowest high-frequency core loss
5. lowest coercivity

**Disadvantages** of Namglass III tape cores:

1. requires case for maximum properties
2. very expensive
3. low  $B_{max}$  (approx. 5500)

Namglass III toroidal tape cores are evaluated with the standard CCFR (constant current / flux reset) test. This method measures the dynamic square-loop response of the core and permits identification of important material parameters. Occasionally, Namglass III is also tested for core loss.

## Cut Tape Cores

The term "tape core" can refer not only to the conventional toroid but also to C and E-Cores made of tape-core lamination materials. The practice is justified because the cores are wound and annealed in the same manner and with the same equipment as the toroidal versions.

The magnetic materials are the same as for toroids with the exception of amorphous material, which may not be available in cut core form at this time. The manufacturing procedure is similar but, instead of being cased, the cores are impregnated with epoxy and cut approximately in half. Three-phase cores also are produced - something that would be physically impossible with a toroid. Because of this flexibility, there is almost no manufacturing size limitation for cut cores. On tape-core materials, however, there is a maximum strip width of 2.00 to 14 inches based on gauge of material. (see Figure 13).

Cut cores do not have cases like tape cores; they are impregnated for mechanical rigidity. However, epoxy impregnation of tape-wound cores tends to re-stress the fragile material, reducing permeability and increasing core loss. As a rule, the performance of the cut tape cores will be significantly worse than the cased toroid. The amount of degradation is not always predictable, but can be of the order of 30% more core loss and 50% reduction of permeability. The tradeoffs are that cut cores are much easier to wind (with copper wire) and additional air gap can

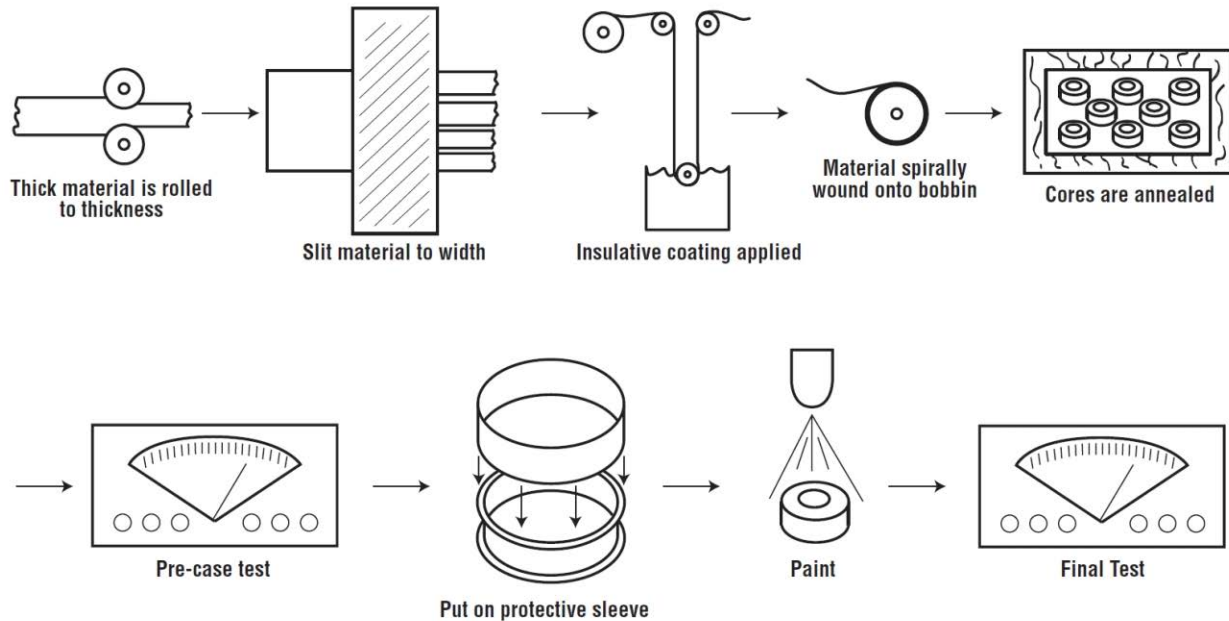

Fig. 14

be added to the core. This last point means that this type of core can be used not only for transformers but also for inductors. The cut tape core generally is considered a high-performance alternative to the Silectron C-Core.

One thing cut tape cores do have in common with toroidal versions is the cost factor: Both are expensive. Applications tend to be more exotic and specialized.

**Advantages** of cut tape cores are:

1. can insert discrete air gap
2. can wind with foils and large-diameter wire
3. easier to wind than toroids
4. lower core loss than Silectron C-Cores
5. Supermendur cut cores allow highest energy capacity

**Disadvantages** of cut tape cores are:

1. expensive
2. higher core loss than toroid
3. lower permeability than toroid
4. hard to make large cores of thinner tape

Testing of cut tape cores is primarily to evaluate them for core loss and exciting losses. Occasionally Bmax will be evaluated.

## Bobbin Tape Wound Cores

A special variant of tape core, the bobbin core is similar to the standard toroid tape core except that, because build-ups of ultra-thin tape generally are quite small, the material is wound on a bobbin which can be plastic, stainless steel or a similar material. Alloy strips used in standard tape-

wound toroids are limited to 1/2 mil thickness, but bobbin cores can be manufactured from tape as thin as 1/8 mil. Manufacturing is similar to the standard toroidal tape core, except that the bobbin defines the ID of the core instead of mandrel. Materials commonly used are Deltamax and Permalloy (see Figure 14).

Bobbin cores are characterized by very high permeability at low flux levels, square loop response, and very low coercivity. They originally were conceived for “core memory” applications which industry is all but extinct and what is left utilizes soft ferrites. The most popular application today is in various **Magnetometer** designs which include compasses and fusing devices for armament, sonobuoys. These utilize the very high permeability of the core material. Another growing application for bobbin cores is as inverter transformers in small, board-mount DC-DC converters.

Because of high material costs and high labor content, bobbin cores tend to be extremely expensive on a per-pound basis.

**Advantages** of bobbin cores are:

1. can wind in ultra-thin tape
2. can be made with very small OD/ID/HT
3. very high permeability
4. impervious to shock because tape is attached to bobbin

**Disadvantages** of bobbin cores are:

5. expensive
6. poor use of space due to presence of bobbin
7. bobbin must be machined to size
8. difficult to manufacture

Testing of bobbin cores normally follows a special pulse test sequence that was designed around the “core memory” application. It is somewhat similar to a CCFR test and does an adequate job of revealing important parameters. Some bobbin core customers provide highly specialized test fixtures that perform application-specific testing.

## Silectron Toroids

Silectron is a grain-oriented, 3.25% Si / 96% Fe alloy. One popular core configuration is the toroid, not unlike the toroidal tape core. Manufacturing of Silectron toroids is virtually identical to that of other toroid tape cores. This type of core is available in a core case, like tape cores, or with epoxy impregnation or epoxy impregnation and epoxy coating. As with cut tape cores, the impregnation process degrades the properties of the material.

Silectron has a moderately high permeability and high flux density. Applications for Silectron toroids are current transformers, low-frequency power transformers, and low-frequency mag amps. Silectron toroids are available in 11, 9, 6, 4, 2, and 1 mil tape thicknesses.

Because of Silectron’s high flux density and low cost, applications are more general in nature than nickel-iron, cobalt-iron, or amorphous toroids.

### Advantages of Silectron toroids:

1. relatively inexpensive
2. high Bmax

### Disadvantages of Silectron toroids are:

1. higher core loss than tape core
2. difficult to wind due to toroidal shape

Testing of Silectron is almost always for cores loss and exciting loss. Occasionally, Bmax or BH loop testing is conducted.

## Silectron C and E-cores

Cut cores made of Silectron are manufactured identically to cut tape cores. The type of insulation used on the tape and the method of anneal may differ but, for the most part, the process is the same.

Like uncut Silectron cores, Silectron C-Cores have moderately high permeability. Without added air gap, they find use in low-frequency power transformers and pulse transformers. With air gap added, they are used in inductor applications. The only limitation to use is core loss.

Silectron is a low-cost material, and applications cover the full spectrum of the marketplace.

### Advantages of Silectron C-Cores:

1. available in three-phase form
2. coil is easy to wind
3. coil can utilize foils and heavy-gauge wire
4. can insert varying amounts of air gap
5. inexpensive
6. high flux capacity

### Disadvantages of Silectron C-Cores:

1. high core loss
2. moderate permeability material
3. air gap lowers permeability

Testing of Silectron C-Cores is predominately for core loss and exciting losses. 1 and 2 mil C-Cores are routinely tested for pulse permeability and this also reveals information about core loss and exciting energy. Special permeability testing, similar to that performed on powder cores, is sometimes performed.

## Distributed Gap Cores

DG (distributed gap, sometimes called “take apart”) cores are a special variation of the Silectron C-Core. They are similar in shape to a C-Core, but the air gap is “distributed” over a portion of the magnetic length. Winding is accomplished by a special machine. The core is not impregnated, and it is assembled onto the coil by the customer. Anneal is the same as other Silectron cores. Only thicker material (9 to 12 mil) is utilized.

This type of core is used almost exclusively for 60 Hz distribution transformers.

Testing is to determine core loss and exciting losses.

## Selection of material by Application

In general, the choice of magnetic material is the result of a trade-off between saturation flux density, energy loss and cost.

Keep in mind the distinction between inductors (energy storage) and transformers (energy transfer) as you review the following analysis showing specific usage.

### LOW-FREQUENCY POWER CONVERSION

Power conversion includes the following specific applications, which could turn up in any number of industries. What is actually being described is an electrical function, not a job-specific device.

#### Distribution power transformers

Silectron C and E-Cores  
Silectron toroids  
Supremendur C and E-Cores (400 HZ) DG cores

## Welding Transformers

Silectron C-Cores

## Rectifier Transformers

Silectron C and E-Cores  
 Supermendur C and E-Cores

## Mag Amps and Saturable Reactors

Silectron C-Cores  
 Silectron toroids  
 Supermendur toroid tape cores  
 Deltamax toroid tape cores  
 Square Permalloy toroid tape cores

## Pulse transformers

Silectron C-Cores  
 Permalloy, Supermalloy, Deltamax, and Supermendur cut cores  
 Permalloy, Supermalloy, Deltamax, Namglass I, Namglass II, and Supermendur toroid tape cores  
 Silectron toroids

## Instrumentation (current and potential transformers)

Silectron C-Cores  
 Silectron toroids  
 Permalloy, Supermalloy, and Deltamax cut cores  
 Permalloy, Supermalloy, Namglass I, and Namglass II toroid tape cores  
 MPP, SUPER-MSS, HI-FLUX

## Power Inductors

Silectron C-Cores  
 Permalloy, Supermalloy, and Deltamax cut cores  
 MPP, SUPER-MSS, HI-FLUX

## EMI Inductors

Silectron C-Cores  
 Permalloy, Supermalloy, and Deltamax cut cores  
 Namglass I and Namglass II toroid tape cores  
 MPP, SUPER-MSS, HI-FLUX

## HIGH-FREQUENCY APPLICATIONS

### D.C. Filters

MPP, SUPER-MSS, HI-FLUX Silectron C-Cores  
 Permalloy, Supermalloy, and Deltamax cut cores

### A.C. Filters

MPP, SUPER-MSS, HI-FLUX  
 Permalloy, Supermalloy, and Deltamax cut cores

### High Q Filters

MPP

### Mag Amp and Saturable Reactor

Square Permalloy and Namglass III toroid tape core

### Power transformers

Namglass II, Permalloy, and Supermalloy toroid tape cores  
 Permalloy, Supermalloy, and Deltamax cut cores

Bobbin cores

## Flyback Transformers

MPP, HI-FLUX and SUPER-MSS

## Instrumentation (current transformers, magnetometers)

Permalloy and Supermalloy toroid tape core  
 Permalloy Bobbins cores

## MAJOR INDUSTRY GROUPS AND TYPICAL APPLICATIONS

### Computer

High-frequency power conversion  
 High-frequency applications  
 Low-frequency power conversion  
 All listed in Low-Frequency power conversion except for welding transformers, pulse trans- formers, and instrumentation magnetics  
 Special Silectron structures  
 High-performance laminated motor parts

### Automotive

High frequency  
 Permalloy bobbin cores for magnetometers used in compasses.  
 MPP, HI-FLUX, SUPER-MSS and Silectron for magnetics used in special ignition systems  
 Low frequency  
 Welding transformers  
 Special Silectron structures for fuel-injection systems

### Motor speed control/Light dimmer

C-Cores for EMI and A.C. filters SUPER-MSS for EMI and A.C. filters  
 Silectron toroids for current transformers Toroid tape cores for current transformers SUPER-MSS for current transformers Silectron toroids for mag amps  
 Toroid tape cores for mag amps

### Instrumentation

Silectron toroids with gaps for Hall effect current sense  
 Toroid tape cores with gaps for Hall effect current sense  
 Permalloy bobbins cores for magnetometers Silectron toroids for current transformers Toroid tape cores for current transformers  
 MPP, HI-FLUX, SUPER-MSS for D.C./A.C. filters  
 Silectron C-Cores for current transformers

### Electrical utility hardware

DG cores for distribution transformers  
 Silectron C-cores used for power factor adjusting inductors  
 Silectron C-Cores and toroids for current trans- formers and for potential transformers

### Medical equipment

- C-cores for HV transformers
- C-cores for EMI filters
- MPP, HI-FLUX and SUPER-MSS for EMI Filters
- High-frequency power conversion. See High-Frequency Applications
- C-Cores for high-efficiency 60 HZ power transformers

#### **Welding and other metal processing**

- C-Cores for high frequency induction furnaces
- C-Cores for step-down welding transformers
- Silectron toroids for current transformers
- Silectron toroids for mag amp control
- Toroid tape for current transformers
- Toroid tape core for mag amp control

#### **Telecommunications**

- MPP for loading coils

- High-frequency power conversion. See High-Frequency Applications
- Low-frequency power conversion. See Low-Frequency conversion

#### **Military hardware**

- High-frequency power conversion. See High-Frequency Applications
- Low-frequency power conversion. See Low-Frequency conversion

#### **Lighting and Plasma Displays**

- High-frequency power conversion. See High-Frequency Applications
- Low-frequency power conversion. See Low-Frequency conversion

MATERIAL	TYPICAL FREQUENCY RANGE	TEMP. RANGE °C	SIZE/SHAPE LIMITATIONS	POWER CAPACITY	COST	ADVANTAGES/ (DISADVANTAGES)
<b>POWER TRANSFORMERS</b>						
<b>Ferrites</b>						
Power Ferrites	10kHz–2 MHz	-55 to 150	E's, toroids, Pot Cores. Limited to 500 cm <sup>3</sup>	Low	Low	High Perm, Low Loss at High Hz (Low Saturation Flux)
High Freq Ferrites	50kHz–1GHz	-55 to 150	E's, toroids, Pot Cores. Limited to 250 cm <sup>3</sup>	Low	Medium	Good perm, Loss at High Hz (Low Saturation Flux)
<b>MPP, HI-FLUX, SUPER-MSS</b>						
MPP	5kHz–200 kHz	-55 to 200	Toroids up to 132 mm	Medium	High	Very Stable (Low Perm usually limits transformer applications to flyback types.)
HI-FLUX	5kHz–50 kHz	-55 to 200	Toroids up to 132 mm	Medium	High	Very Stable, High Saturation (Low Perm usually limits transformer applications to flyback types.)
SUPER-MSS	5 kHz–200 kHz	-55 to 200	Toroids up to 132 mm	Medium	Medium	Very Stable, High Saturation (Low Perm usually limits transformer applications to flyback types.)
<b>Powdered Iron</b>						
High Perm	NR	NR	NR	NR	NR	(High Loss, Low Perm)
Medium Perm	25 kHz–1MHz	-55 to 155	Unlimited to 350 cm <sup>3</sup>	Medium	Low	Low Loss, Good Stability (Low Perm)
Low Perm	1MHz–1 GHz	-55 to 155	Unlimited to 350 cm <sup>3</sup>	Medium	Low	Low Loss, Good Stability (Low Perm)
<b>Tape Cores</b>						
Ni-Fe	50 Hz–100kHz	-55 to 200	Toroids Unlimited Size	High	High	Highest Perm, Square Loop, High Saturation (High Cost, Toroids)
Si-Fe	50 Hz–10 kHz	-55 to 350	Toroids Unlimited Size	Very High	Medium	High Perm, High Saturation Flux (Core Loss, Toroids Only)
Co-Fe	50 Hz–1 kHz	-55 to 450	Toroids Unlimited Size	Very High	Very High	Highest Saturation Flux (High Cost, 4 mil only, Toroids only)
Amorphous	50 Hz–500 kHz	-55 to 175	Toroids to 130 mm	High	High	Low Loss, High Saturation Flux (High Cost, Toroids Only)

MATERIAL	TYPICAL FREQUENCY RANGE	TEMP. RANGE °C	SIZE/SHAPE LIMITATIONS	POWER CAPACITY	COST	ADVANTAGES/ (DISADVANTAGES)
<b>POWER TRANSFORMERS (Cont.)</b>						
<b>Cut Cores</b>						
Si-Fe	50 Hz–10 kHz	-55 to 175	Toroids, E's & U's Unlimited Size	Very High	High	Good Perm, High Saturation Flux (Core Loss, Air Gap Effects)
Ni-Fe	50 Hz–100 kHz	-55 to 175	Toroids, E's & U's Unlimited Size	High	High	High Perm, High Saturation Flux (High Cost, Air Gap Effects)
Co-Fe	50 Hz–1 kHz	-55 to 175	Toroids, E's & U's Unlimited Size	Very High	Very High	Highest Saturation Flux (Highest Cost, Air Gap Effects)
<b>Bobbin Core</b>						
Ni-Fe	5 kHz–1 MHz	-55 to 200	Small Toroids	Low	High	Low Loss, High Perm (Small Size, Toroids)
<b>Dist. Gap</b>						
Si-Fe	50–60 Hz	-55 to 200	Single Phase, Three	Very High	Low	High Perm, Small Air Gap (Low Frequency Only, Si-Fe Only)
<b>Scrapless Lams and Shearings</b>						
Si-Fe, Co-Fe, and Ni-Fe	50–60 Hz	-55 to 200	Single Phase, Three Phase, Unlimited Size	Very High	Low	High Perm, Small Air Gap Unlimited Size (Low Frequency Only, Si-Fe Only)
<b>RF TRANSFORMERS</b>						
<b>Ferrites</b>						
Power Ferrites	1 MHz–5 MHz	-55 to 150	Mostly Cyl, Pot Cores. Other small Shapes	Low	Low	High Perm, Tunable, High Q (Poor Stability, Mu Tolerance)
High Freq Ferrites	1 MHz–1 GHz	-55 to 150	Toroids Pot Cores Small Shapes	Low	Medium	Good perm, Tunable High Q at High Frequency
<b>MPP, HI-FLUX, SUPER-MSS</b>						
MPP	1 MHz–2 MHz	-55 to 200	Toroids up to 132 mm	Low	High	Very Stable (Low Perm, Lower Q than Ferrite)
HI-FLUX	NR	NR	NR	NR	NR	(High Loss)
SUPER-MSS	NR	NR	NR	NR	NR	
<b>Powdered Iron</b>						
High Perm	NR	NR	NR	NR	NR	(High Loss)
Medium Perm	1 MHz–10 MHz	-55 to 155	Unlimited to 350 cm <sup>3</sup>	Medium	Medium	Good Stability
Low Perm	10 MHz–500 MHz	-55 to 155	Unlimited to 350 cm <sup>3</sup>	Medium	Medium	Low Loss, Good Stability (Low Perm)

MATERIAL	TYPICAL FREQUENCY RANGE	TEMP. RANGE °C	SIZE/SHAPE LIMITATIONS	POWER CAPACITY	COST	ADVANTAGES/ (DISADVANTAGES)
<b>RF TRANSFORMERS (Cont.)</b>						
<b>Tape Cores</b>						
Ni-Fe	1 MHz–2 MHz	-55 to 200	Toroids Unlimited Size	High	High	High Perm (Good Q at Low Flux Only, High Cost, Toroids Only)
Si-Fe	NR	NR	NR	NR	NR	(High Loss)
Co-Fe	NR	NR	NR	NR	NR	(High Loss)
Amorphous	1 MHz–2 MHz	-55 to 175	Toroids to 130 mm	High	High	Low Loss, High Saturation Flux (High Cost, Toroids Only)
<b>Cut Cores</b>						
Si-Fe	NR	NR	NR	NR	NR	(High Loss)
Ni-Fe	NR	NR	NR	NR	NR	(High Loss)
Co-Fe	NR	NR	NR	NR	NR	(High Loss)
<b>Bobbin Core</b>						
Ni-Fe	1 MHz–5 MHz	-55 to 200	Small Toroids	Low	High	Low Loss, High Perm (Small Size Low Flux for High Q)
<b>Dist. Gap</b>						
Si-Fe	NR	NR	NR	NR	NR	(High Loss)
<b>Scrapless Lams and Shearings</b>						
Si-Fe, Co-Fe, and Ni-Fe	NR	NR	NR	NR	NR	(High Loss)
<b>PRECISION TRANSFORMERS</b>						
<b>Ferrites</b>						
Power Ferrites	10 kHz–5 MHz	-55 to 150	E's, toroids, Pot Cores. Limited to 500 cm <sup>3</sup>	Medium	Low	Good Perm, Low Loss at High Frequency (Low Saturation Flux)
High Freq	NR	NR	NR	NR	NR	(Low Perm)
<b>MPP, HI-FLUX, SUPER-MSS</b>						
MPP	DC–500 kHz	-55 to 200	Toroids up to 132 mm.	Very Low	High	Low Perm is useful in sensing applications where high frequency, small-signals are superposed on high-current conductors.
HI-FLUX	NR	NR	NR	NR	NR	(Low Perm)
SUPER-MSS	NR	NR	NR	NR	NR	(Low Perm)



MATERIAL	TYPICAL FREQUENCY RANGE	TEMP. RANGE °C	SIZE/SHAPE LIMITATIONS	POWER CAPACITY	COST	ADVANTAGES/ (DISADVANTAGES)
<b>PRECISION TRANSFORMERS (Cont.)</b>						
<b>Powdered Iron</b>						
High Perm	NR	NR	NR	NR	NR	(Low Perm)
Medium Perm	NR	NR	NR	NR	NR	(Low Perm)
Low Perm	NR	NR	NR	NR	NR	(Low Perm)
<b>Tape Cores</b>						
Ni-Fe	to approx 10 MHz	-55 to 200	Toroids Unlimited Size	High	High	Highest Perm, Best Accuracy, High Sat. (High Cost, Toroids)
Si-Fe	50 Hz–10 kHz	-55 to 350	Toroids Unlimited Size	Very High	Low	Good Perm, High Saturation Flux (Core Loss, Toroids Only)
Co-Fe	50 Hz–1 kHz	-55 to 450	Toroids Unlimited Size	Very High	Very High	Highest Saturation Flux, Magnetostrictive (High Cost, Losses)
Amorphous	50 Hz–2 MHz	-55 to 175	Toroids Unlimited Size	High	Very	Low Loss, High Saturation Flux (High Cost, Toroids Only)
<b>Cut Cores</b>						
Si-Fe	50 Hz–10 kHz	-55 to 175	Toroids, E's & U's Unlimited Size	Very High	Low	Good Perm, High Saturation Flux (Core Loss, Air Gap Effects)
Ni-Fe	50 Hz–100 kHz	-55 to 175	Toroids, E's & U's Unlimited Size	High	High	High Perm, High Saturation Flux (High Cost, Air Gap Effects)
Co-Fe	50 Hz–1 kHz	-55 to 175	Toroids, E's & U's Unlimited Size	Very High	Very High	Highest Saturation Flux (Highest Cost, Air Gap Effects)
<b>Bobbins Core</b>						
Ni-Fe	to 2 MHz	-55 to 200	Small Toroids	Low	High	Low Loss, High Perm, Ultra thin Tapes (Small Size, Toroids Only)
<b>Dist. Gap</b>						
Si-Fe	50–60 Hz	-55 to 200	Single Phase, Three Phase	Very High	Low	High Perm, Small Air Gap (Low Frequency Only, Si-Fe Only)
<b>Scrapless Lam and Shearing</b>						
Si-Fe, Co-Fe, and Ni-Fe	50–60Hz	-55 to 200	Single Phase, Three Phase, Unlimited Size	Very High	Low	High Perm, Small Air Gap, Unlimited Size (Low Frequency Only, 9-12 mil Si-Fe Only)

MATERIAL	TYPICAL FREQUENCY RANGE	TEMP. RANGE °C	SIZE/SHAPE LIMITATIONS	POWER CAPACITY	COST	ADVANTAGES/ (DISADVANTAGES)
<b>SATURABLE REACTORS</b>						
<b>Ferrites</b>						
Power Ferrites	10kHz–2 MHz	-55 to 150	E's, toroids, Pot Cores. Limited to 500 cm <sup>3</sup>	Low	Low	Good Perm, Low Core Loss (Low Saturation Flux, High Hysteresis)
High Freq Ferrites	NR	NR	NR	NR	NR	(Low Perm)
<b>MPP, HI-FLUX, SUPER-MSS</b>						
MPP	NR	NR	NR	NR	NR	(Low Perm)
HI-FLUX	NR	NR	NR	NR	NR	(Low Perm)
SUPER-MSS	NR	NR	NR	NR	NR	(Low Perm)
<b>Powdered Iron</b>						
High Perm	NR	NR	NR	NR	NR	(Low Perm)
Medium Perm	NR	NR	NR	NR	NR	(Low Perm)
Low Perm	NR	NR	NR	NR	NR	(Low Perm)
<b>Tape Cores</b>						
Ni-Fe	50 Hz–100 kHz	-55 to 200	Toroids Unlimited Size	High	High	Highest Perm, Square Loop, High Saturation (High Cost, Toroids)
Si-Fe	50 Hz–10 kHz	-55 to 350	Toroids Unlimited Size	Very High	Medium	Good Perm, High Saturation Flux, Good Squareness (Core Loss)
Co-Fe	50 Hz–1 kHz	-55 to 450	Toroids Unlimited Size	Very High	Very High	Highest Saturation Flux, Square Loop (High Cost, 4 mil Only)
Amorphous	50 Hz–2 kHz	-55 to 175	Toroids to 130 mm	High	High	Low Loss, Ultra Square Loop (High Cost, Toroids Only)
<b>Cut Cores</b>						
Si-Fe	50 Hz–10 kHz	-55 to 175	Toroids, E's & U's Unlimited Size	Very High	Low	Good Perm, High Saturation Flux (Core Loss, Air Gap Effects)
Ni-Fe	50 Hz–100 kHz	-55 to 175	Toroids, E's & U's Unlimited Size	High	High	High Perm, High Saturation Flux (High Cost, Air Gap Effects)
Co-Fe	50 Hz–1 kHz	-55 to 175	Toroids, E's & U's Unlimited Size	Very High	Very High	Very High Saturation Flux (Highest Cost, Air Gap Effects)
<b>Bobbin Core</b>						
Ni-Fe	5 kHz–2 MHz	-55 to 200	Small Toroids	Low	High	Low Loss, High Perm, Very Square (Small Size, Toroids)

MATERIAL	TYPICAL FREQUENCY RANGE	TEMP. RANGE °C	SIZE/SHAPE LIMITATIONS	POWER CAPACITY	COST	ADVANTAGES/ (DISADVANTAGES)
<b>SATURABLE REACTORS (Cont.)</b>						
<b>Dist. Gap</b>						
Si-Fe	50–60 Hz	-55 to 200	Single Phase, Three Phase	Very High	Low	High Perm, Small Air Gap (Low Frequency Only, Thick mil Only)
<b>Scrapless Lams and Shearings</b>						
Si-Fe, Co-Fe, and Ni-Fe	50–60 Hz	-55 to 200	Single Phase, Three Phase, Unlimited Size	Very High	Low	High Perm, Small Air Gap, Unlimited Size (Low Frequency Only, Thick mil Si-Fe Only)
<b>PURE INDUCTORS</b>						
<b>Ferrites</b>						
Power Ferrites	10 kHz–5 MHz	-55 to 150	E's, toroids, Pot Cores. Limited to 500 cm <sup>3</sup>	Low	Low	High Perm, Low Loss, Tunable (Low Saturation Flux, Poor Stability)
High Freq Ferrites	50kHz–1 GHz	-55 to 150	E's, toroids, Pot Cores. Limited to 250 cm <sup>3</sup>	Medium	Medium	Good perm, Low Loss, Tunable (Low Saturation, Poor Stability)
<b>MPP, HI-FLUX, SUPER-MSS</b>						
MPP	DC-300 kHz	-55 to 200	Toroids up to 132 mm	High	High	Very Stable, High Saturation, Low Magnetostriction, Lowest Loss of Powder Materials
HI-FLUX	DC-100 kHz	-55 to 200	Toroids up to 132 mm	Very High	High	Very Stable, Higher Saturation than MPP or Super-MSS
SUPER-MSS	DC-300 kHz	-55 to 200	Toroids up to 132 mm	High	Medium	Very Stable, High Saturation, Low Magnetostriction, Low Loss
<b>Powdered Iron</b>						
High Perm	1 kHz–50 kHz	-55 to 175	Toroids up to 132 mm	High	Low	High Saturation, Low Cost (Core Loss, Low Perm)
Medium Perm	50 kHz–2 MHz	-55 to 155	Unlimited to 350 cm <sup>3</sup>	High	Low	Low Loss, Good Stability (Low Perm)
Low Perm	1 MHz–500 MHz	-55 to 155	Unlimited to 350 cm <sup>3</sup>	High	Medium	Low Loss, Good Stability (Low Perm)
<b>Tape Cores</b>						
Ni-Fe	50 Hz–500 kHz	-55 to 200	Toroids Unlimited Size	Low	High	Highest Perm, High Saturation (High Cost, Low Energy)
Si-Fe	50 Hz–10 kHz	-55 to 350	Toroids Unlimited Size	Low	Medium	High Perm, High Saturation Flux (Core Loss, Low Energy)
Co-Fe	50 Hz–1 kHz	-55 to 450	Toroids Unlimited Size	Low	Very High	Highest Saturation Flux (High Cost, 4 mil Only, Low Energy)
Amorphous	50 Hz–500 kHz	-55 to 175	Toroids to 130 mm	Low	High	Low Loss, High Saturation Flux (High Cost, Low Energy)

MATERIAL	TYPICAL FREQUENCY RANGE	TEMP. RANGE °C	SIZE/SHAPE LIMITATIONS	POWER CAPACITY	COST	ADVANTAGES/ (DISADVANTAGES)
<b>PURE INDUCTORS (Cont.)</b>						
<b>Cut Cores</b>						
Si-Fe	50 Hz–10 kHz	-55 to 175	Toroids, E's & U's Unlimited Size	Very High	Medium	Good Perm, High Saturation Flux (Core Loss)
Ni-Fe	50 Hz–100 kHz	-55 to 175	Toroids, E's & U's Unlimited Size	High	High	High Perm, High Saturation Flux (High Cost)
Co-Fe	50 Hz–1 kHz	-55 to 175	Toroids, E's & U's Unlimited Size	Very High	Very High	Highest Saturation Flux (Highest Cost)
<b>Bobbin Core</b>						
Ni-Fe	5 kHz–1 MHz	-55 to 200	Small Toroids	Very Low	High	Low Loss, High Perm (Small Size, Toroids)
<b>Dist. Gap</b>						
Si-Fe	50–60 Hz	-55 to 200	Single Phase, Three Phase	Low	Low	High Perm, Small Air Gap (Low Frequency Only, Thick mil Only)
<b>Scrapless Lams and Shearings</b>						
Si-Fe, Co-Fe, and Ni-Fe	50–60 Hz	-55 to 200	Single Phase, Three Phase, Unlimited Size	Very High	Low	High Perm, Small Air Gap, Unlimited Size (Low Frequency Only, Thick mil Si-Fe Only)
<b>EMI FILTERS</b>						
<b>Ferrites</b>						
Power Ferrites	10 kHz–5 MHz	-55 to 150	E's, toroids, Pot Cores. Limited to 500 cm <sup>3</sup>	Low	Low	High Perm, Low Loss (Low Saturation Flux, Poor Stability)
High Freq Ferrites	50 kHz–1 GHz	-55 to 150	E's, toroids, Pot Cores. Limited to 250 cm <sup>3</sup>	Medium	Medium	Good perm, Low Loss (Low Saturation Flux, Poor Stability)
<b>MPP, HI-FLUX, SUPER-MSS</b>						
MPP	DC-1 MHz	-55 to 200	Toroids up to 132 mm	High	High	Very Stable, High Saturation, Low Magnetostriction, Wide Range of Permeability
HI-FLUX	DC-300 kHz	-55 to 200	Toroids up to 132 mm	Very High	High	Very Stable, Higher Saturation than MPP or Super-MSS
SUPER-MSS	DC-1 MHz	-55 to 200	Toroids up to 132 mm	High	Medium	Very Stable, High Saturation, Low Magnetostriction

MATERIAL	TYPICAL FREQUENCY RANGE	TEMP. RANGE °C	SIZE/SHAPE LIMITATIONS	POWER CAPACITY	COST	ADVANTAGES/ (DISADVANTAGES)
<b>EMI FILTERS (Cont.)</b>						
<b>Powdered Iron</b>						
High Perm	50 kHz–500 kHz	-55 to 175	Toroids up to 132 mm	High	Low	High Saturation, Low Cost (Core Loss)
Medium Perm	50 kHz–2 MHz	-55 to 155	Unlimited to 350 cm <sup>3</sup>	High	Low	Low Loss, Good Stability (Low Perm)
Low Perm	2 MHz–500 MHz	-55 to 155	Unlimited to 350 cm <sup>3</sup>	High	Medium	Low Loss, Good Stability (Low Perm)
<b>Tape Cores</b>						
Ni-Fe	50 Hz–2 MHz	-55 to 200	Toroids Unlimited Size	Low	High	Highest Perm, High Saturation (High Cost, Low Energy)
Si-Fe	50 Hz–10kHz	-55 to 350	Toroids Unlimited Size	Low	Medium	High Perm, High Saturation Flux (Core Loss, Low Energy)
Co-Fe	50 Hz-1 kHz	-55 to 450	Toroids Unlimited Size	Low	Very High	Highest Saturation Flux (High Cost, 4 mil Only, Low Energy)
Amorphous	50 Hz–2 MHz	-55 to 175	Toroids Unlimited Size	Low	High	Low Loss, High Saturation Flux (High Cost, Low Energy)
<b>Cut Cores</b>						
Si-Fe	50 Hz–10 kHz	-55 to 175	Toroids, E's & U's Unlimited Size	Very High	Medium	Good Perm, High Saturation Flux (Core Loss, Requires Air Gap)
Ni-Fe	50 Hz–250 kHz	-55 to 175	Toroids, E's & U's Unlimited Size	High	High	High Perm, High Saturation Flux (High Cost, Requires Air Gap)
Co-Fe	50 Hz–1 kHz	-55 to 175	Toroids, E's & U's Unlimited Size	Very High	Very High	Highest Saturation Flux (Highest Cost, Requires Air Gap)
<b>Bobbin Cores</b>						
Ni-Fe	5 kHz–1 MHz	-55 to 200	Small Toroids	Very Low	High	Low Loss, High Perm (Small Size, Low Energy)
<b>Dist. Gap</b>						
Si-Fe	50–60 Hz	-55 to 200	Single Phase, Three Phase	Medium	Low	High Perm, Small Air Gap (Low Frequency Only, Thick mil Only)
<b>Scrapless Lams and Shearings</b>						
Si-Fe, Co-Fe, and Ni-Fe	50–60 Hz	-55 to 200	Single Phase, Three Phase, Unlimited Size	Very High	Low	High Perm, Unlimited Size (Low Frequency Only, Thick mil Si-Fe Only, Requires Air Gap)

MATERIAL	TYPICAL FREQUENCY RANGE	TEMP. RANGE °C	SIZE/SHAPE LIMITATIONS	POWER CAPACITY	COST	ADVANTAGES/ (DISADVANTAGES)
<b>ENERGY STORAGE INDUCTORS</b>						
<b>Ferrites</b>						
Power Ferrites	10 kHz–500 kHz	-55 to 150	E's, toroids, Pot Cores. Limited to 500 cm <sup>3</sup>	Medium	Low	High Perm, Low Loss, Tunable (Low Saturation, Requires Gap)
High Freq Ferrites	50 kHz–500 MHz	-55 to 150	E's, toroids, Pot Cores. Limited to 250 cm <sup>3</sup>	Medium	Medium	Good perm, Low Loss, Tunable (Low Saturation, Poor Stability)
<b>MPP, HI-FLUX, SUPER-MSS</b>						
MPP	DC-300 kHz	-55 to 200	Toroids up to 132 mm	High	High	Very Stable, High Saturation, Low Magnetostriction, Lowest Loss of Powder Materials
HI-FLUX	DC-100 kHz	-55 to 200	Toroids up to 132 mm	Very High	High	Very Stable, Higher Saturation than MPP or Super-MSS
SUPER-MSS	DC-300 kHz	-55 to 200	Toroids up to 132 mm	High	Medium	Very Stable, High Saturation, Low Magnetostriction, Low Loss
<b>Powdered Iron</b>						
High Perm	1 kHz–100 kHz	-55 to 175	Toroids up to 132 mm	High	Low	High Saturation, Low Cost (Core Loss)
Medium Perm	50 kHz–2 MHz	-55 to 155	Unlimited to 350 cm <sup>3</sup>	High	Low	Low Loss, Good Stability (Low Perm)
Low Perm	1 MHz–500 MHz	-55 to 155	Unlimited to 350 cm <sup>3</sup>	High	Medium	Low Loss, Good Stability (Low Perm)
<b>Tape Cores</b>						
Ni-Fe	NR	NR	NR	NR	NR	(High Perm)
Si-Fe	NR	NR	NR	NR	NR	(High Perm)
Co-Fe	NR	NR	NR	NR	NR	(High Perm)
Amorphous	NR	NR	NR	NR	NR	(High Perm)
<b>Cut Cores</b>						
Si-Fe	50 Hz–100 kHz	-55 to 175	Toroids, E's & U's Unlimited Size	Very High	Medium	Good Perm, High Saturation Flux (Core Loss, Requires Air Gap)
Ni-Fe	50 Hz–250 kHz	-55 to 175	Toroids, E's & U's Unlimited Size	High	High	High Perm, High Saturation Flux (High Cost, Requires Air Gap)
Co-Fe	50 Hz–1 kHz	-55 to 175	Toroids, E's & U's Unlimited Size	Very High	Very High	Highest Saturation Flux (Highest Cost, Requires Air Gap)
<b>Bobbin Core</b>						
Ni-Fe	NR	NR	NR	NR	NR	(High Perm)
<b>Dist. Gap</b>						
Si-Fe	NR	NR	NR	NR	NR	(High Perm)
<b>Scrapless Lams and Shearings</b>						
Si-Fe, Co-Fe, and Ni-Fe	50–60 Hz	-55 to 200	Single Phase, Three Phase, Unlimited Size	Very High	Low	High Perm, Unlimited Size (Low Frequency Only, Requires Air Gap)



770 Linden Avenue • Rochester • NY 14625 USA  
800-593-9127 • (+1) 585-385-9010 • Fax: (+1) 585-385-9017  
E-mail: [infoNA@arnoldmagnetics.com](mailto:infoNA@arnoldmagnetics.com)  
[www.arnoldmagnetics.com](http://www.arnoldmagnetics.com)

**Disclaimer of Liability**

Arnold Magnetic Technologies and affiliated companies (collectively "Arnold") make no representations about the suitability of the information and documents, including implied warranties of merchantability and fitness for a particular purpose, title and non-infringement. In no event will Arnold be liable for any errors contained herein for any special, indirect, incidental or consequential damages or any other damages whatsoever in connection with the furnishing, performance or use of such information and documents. The information and documents available herein is subject to revision or change without notice.

**Disclaimer of Endorsement**

Reference herein to any specific commercial product, process, or service by trade name, trademark, manufacturer, or otherwise, does not constitute or imply its endorsement, recommendation, or favoring by Arnold. The information herein shall not be used for advertising or product endorsement purposes without the express written consent of Arnold.

**Copyright Notice**

Copyright 2015 Arnold Magnetic Technologies Corporation. All rights reserved.