

High Precision, Programmable Linear Hall Effect Sensor IC with EEPROM, SENT and PWM Output Protocols, and Advanced Output Linearization

Last-Time Buy

These parts are in production but have been determined to be LAST TIME BUY. This classification indicates that the product is obsolete and notice has been given. Sale of this device is currently restricted to existing customer applications. The device should not be purchased for new design applications because of obsolescence in the near future. Samples are no longer available.

Date of status change: December 5, 2018

Deadline for receipt of LAST TIME BUY orders: December 27, 2019

Recommended Substitutions:

For existing customer transition, and for new customers or new applications, contact Allegro Sales.

NOTE: For detailed information on purchasing options, contact your local Allegro field applications engineer or sales representative.

Allegro MicroSystems reserves the right to make, from time to time, revisions to the anticipated product life cycle plan for a product to accommodate changes in production capabilities, alternative product availabilities, or market demand. The information included herein is believed to be accurate and reliable. However, Allegro MicroSystems assumes no responsibility for its use; nor for any infringements of patents or other rights of third parties which may result from its use.

High Precision, Programmable Linear Hall Effect Sensor IC with EEPROM, SENT and PWM Output Protocols, and Advanced Output Linearization

FEATURES AND BENEFITS

- Advanced 32-segment output linearization functionality enables high output accuracy and linearity in the presence of non-linear input magnetic fields
- Selectable digital SENT (Single Edge Nibble Transmission) or PWM (Pulse Width Modulation) output
- SENT output is SAEJ2716 JAN2010 compliant Allegro Proprietary Enhanced Programmable Features
- Customer programmable sensitivity offset, bandwidth, output polarity, output clamps, 1st and 2nd order temperature compensation
- Simultaneous programming of all parameters for accurate and efficient system optimization
- Factory trimmed magnetic input range (coarse sensitivity) and signal offset
- Sensitivity temperature coefficient and magnetic offset drift preset at Allegro, for maximum device accuracy without requiring customer temperature testing
- Temperature-stable, mechanical stress immune, and extremely low noise device output via proprietary four-phase chopper stabilization and differential circuit design techniques
- Diagnostics for open circuit, overvoltage, and undervoltage
- Wide ambient temperature range: -40°C to 150°C
- Operates with 4.5 to 5.5 V supply voltage

Package: 4-pin SIP (suffix KT)

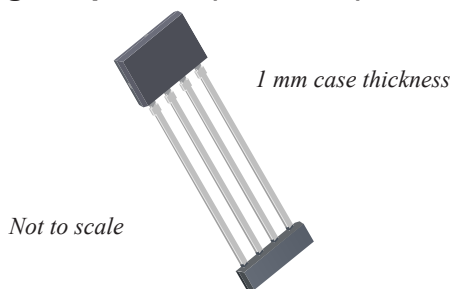

DESCRIPTION

The A1341 device is a high precision, programmable Hall effect linear sensor integrated circuit (IC) with a configurable pulse width modulated (PWM) or single edge nibble transmission (SENT) output, for both automotive and non-automotive applications. The signal path of the A1341 provides flexibility through external programming that allows the generation of an accurate, and customized output voltage from an input magnetic signal. The A1341 provides 12 bits of output resolution, and supports a maximum bandwidth of 3 kHz.

The BiCMOS, monolithic integrated circuit incorporates a Hall sensor element, precision temperature-compensating circuitry to reduce the intrinsic sensitivity and offset drift of the Hall element, a small-signal high-gain amplifier, proprietary dynamic offset cancellation circuits, and advanced output linearization circuitry.

With on-board EEPROM and advanced signal processing functions, the A1341 provides an unmatched level of customer reprogrammable options for characteristics such as gain and offset, bandwidth, output clamps, and output polarity. Multiple input magnetic range and signal offset choices can be preset at the factory. In addition, the device supports separate hot and cold, 1st and 2nd order temperature compensation.

A key feature of the A1341 is its ability to produce a highly linear device output for nonlinear input magnetic fields. To achieve this, the device divides the output into 32 equal segments and applies a unique linearization coefficient factor to each segment. Linearization coefficients are stored in a look-up table in EEPROM.

The A1341 is available in a lead (Pb) free 4-pin single in-line package (KT suffix), with 100% matte tin leadframe plating.

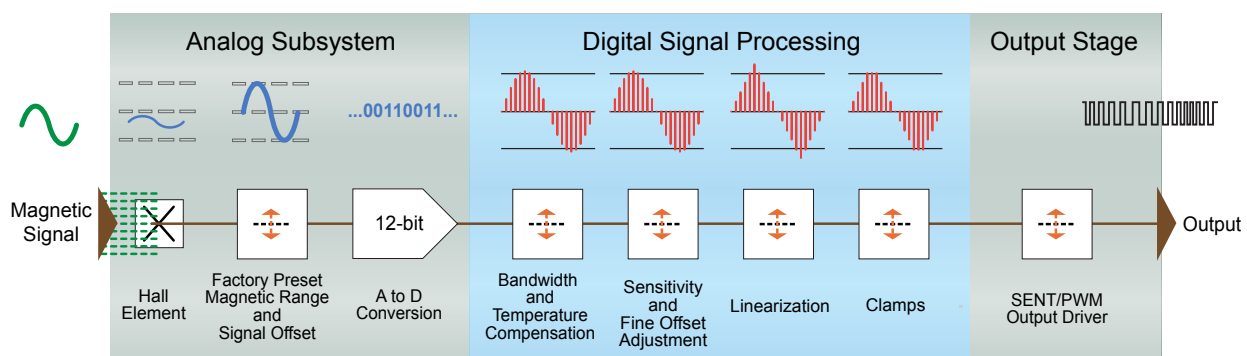

Figure 1: A1341 Signal Processing Path
Functions with programmable parameters indicated by double-headed arrows.

SELECTION GUIDE

Part Number	Packing*
A1341LKTTN-T	4000 pieces per 13-in. reel



*Contact Allegro™ for additional packing options

Table of Contents

Specifications	3	Writing to EEPROM	19
Absolute Maximum Ratings	3	Reading from EEPROM	20
Thermal Characteristics	3	Error Checking	20
Functional Block Diagram	4	Serial Interface Reference	21
Pin-out Diagram and Terminal List	4	Serial Interface Message Structure	22
Electrical Characteristics	5	Linear Output Protocols	27
Magnetic Characteristics	6	PWM Output Mode	27
Programmable Characteristics	7	SENT Output Mode	28
Characteristic Performance	9	Message Structure	28
Functional Description	12	Optional Serial Output Protocol	29
Signal Processing Parameter Setting	12	Data Nibble Format	29
Digital Signal Processing	13	Pause Pulse Timing Synchronization	29
Bandwidth Selection	13	EEPROM Structure	34
Temperature Compensation	13	EEPROM Customer-Programmable Parameter	
Sensitivity (Gain) Adjustment	15	Reference	36
Output Fine Offset Adjustment	15	Definitions of Terms	49
Linearization of Output	15	Full Scale (FSI and FSO)	49
Output Polarity	16	Power-On Time (t_{PO})	49
Output Clamps Setting	16	Signal Propagation Delay (t_{PROP})	49
Output Protocol Selection	16	Signal Response Time (t_{RESP})	49
Protection Features	17	Quiescent Output (QOUT)	49
Operating Voltage and Low Voltage		Quiescent Output Drift through Temperature	
Protection	17	Range	49
Open Circuit Detection	17	Sensitivity (Sens)	49
Typical Application	17	Sensitivity Drift through Temperature Range	50
EEPROM Lock Features	18	Sensitivity Drift Due to Package Hysteresis	
Memory Locking Mechanisms	18	($\Delta Sens_{PKG}$)	50
Programming Serial Interface	19	Linear Sensitivity Error	50
Transaction Types	19	Package Outline Drawing	51
Writing the Access Code	19		

SPECIFICATIONS

Absolute Maximum Ratings

Characteristic	Symbol	Notes	Rating	Unit
Forward Supply Voltage	V_{CC}		30	V
Reverse Supply Voltage	V_{RCC}		-20	V
Forward Supply Current	I_{CC}		30	mA
Reverse Supply Current	I_{RCC}		-30	mA
Forward Output Voltage (OUT Pin)	V_{OUT}		30	V
Reverse Output Voltage (OUT Pin)	V_{ROUT}		-0.5	V
Forward Output Sink Current (OUT Pin)	I_{SINK}		50	mA
Maximum Number of EEPROM Write Cycles	EEPROM _{W(max)}		100	cycle
Operating Ambient Temperature	T_A	L temperature range	-40 to 150	°C
Maximum Junction Temperature	$T_J(max)$		165	°C
Storage Temperature	T_{stg}		-65 to 165	°C

Thermal Characteristics may require derating at maximum conditions, see application information

Characteristic	Symbol	Test Conditions*	Value	Unit
Package Thermal Resistance	$R_{\theta JA}$	1-layer PCB with copper limited to solder pads	174	°C/W

*Additional thermal information available on the Allegro website.

Power Dissipation versus Ambient Temperature

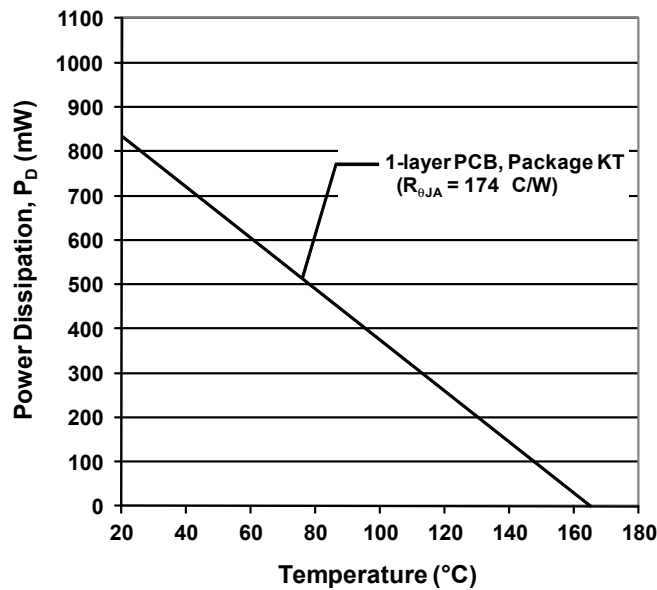

A1341

High Precision, Programmable Linear Hall Effect Sensor IC with EEPROM, SENT and PWM Output Protocols, and Advanced Output Linearization

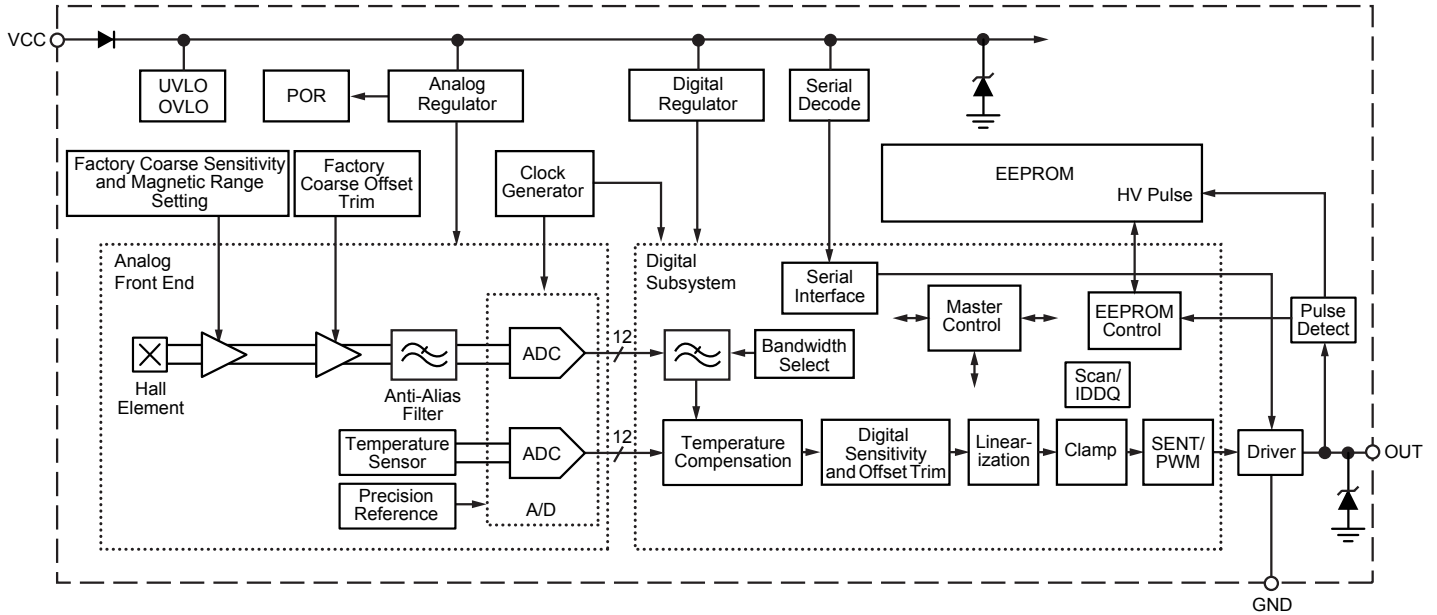

Functional Block Diagram

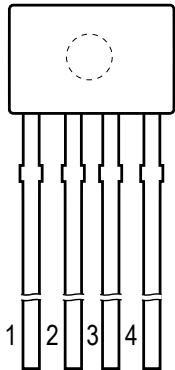

Pinout Diagram

Terminal List Table

Number	Name	Function
1	VCC	Input power supply, use bypass capacitor to connect to ground
2	OUT	Output pin; EEPROM strobe input
3	NC	Not connected; connect to GND for optimal ESD performance
4	GND	Device ground

**ELECTRICAL CHARACTERISTICS: Valid through full operating temperature range, T_A , and supply voltage, V_{CC} ,
 $C_{BYPASS} = 10 \text{ nF}$, unless otherwise specified**

Characteristics	Symbol	Test Conditions	Min.	Typ.	Max.	Unit [1]
GENERAL ELECTRICAL CHARACTERISTICS						
Supply Voltage	V_{CC}		4.5	–	5.5	V
Supply Current	I_{CC}		4	–	10	mA
Reverse Supply Current	I_{RCC}	$V_{RCC} = 20 \text{ V}$	–	–	–5	mA
Supply Zener Clamp Voltage	$V_{ZSUPPLY}$	$I_{CC} = I_{CC(max)} + 3 \text{ mA}$, $T_A = 25^\circ\text{C}$	30	–	–	V
Hall Chopping Frequency [3]	f_C	$T_A = 25^\circ\text{C}$	–	128	–	kHz
Low Voltage Detection Threshold	$V_{CC(LVD)LOW}$	LVD_DIS = 0	4.25	4.4	4.55	V
	$V_{CC(LVD)HIGH}$	LVD_DIS = 0	4.35	4.5	4.7	V
Power-On Reset	POR _{LOW}		3.5	3.7	4.1	V
	POR _{HIGH}		3.6	3.8	4.15	V
Overvoltage Lockout Threshold	$V_{CC(OV)}$	OVLO_LO = 1, $T_A = 25^\circ\text{C}$	5.6	–	–	V
		OVLO_LO = 0, $T_A = 25^\circ\text{C}$	18	–	–	V
SENT Message Duration [3]	t_{SENT}	Tick time = 3 μs	–	–	1	ms
Minimum Programmable SENT Message Duration [3]	$t_{SENTMIN}$	Tick time = 0.25 μs , 3 data nibbles of information, nibble length = 27 ticks	–	41	–	μs
OUTPUT ELECTRICAL CHARACTERISTICS						
Output Saturation Voltage	V_{SAT}	$V_{CC} = 4.5 \text{ V}$, $I_{SINK} = 4.6 \text{ mA}$	–	0.3	0.45	V
Output Current Limit	I_{LIMIT}	Output FET on, $T_A = 25^\circ\text{C}$	20	35	50	mA
Output Zener Clamp Voltage	V_{ZOUT}	$T_A = 25^\circ\text{C}$	30	–	–	V
Output Load Capacitance [3][4]	C_{LOAD}	OUT to GND	–	–	10	nF
Power-On Time [5][6]	t_{PO}	BW = 3000 Hz	–	0.5	–	ms
		BW = 1500 Hz	–	0.8	–	ms
		BW = 750 Hz	–	2	–	ms
		BW = 375 Hz	–	3	–	ms
		BW = 188 Hz	–	6	–	ms
Signal Propagation Delay [3][6]	t_{PROP}	BW = 3000 Hz	–	0.35	–	ms
		BW = 1500 Hz	–	0.7	–	ms
		BW = 750 Hz	–	1.4	–	ms
		BW = 375 Hz	–	2.8	–	ms
		BW = 188 Hz	–	5.6	–	ms
Full Scale Output Range [3]	FSO	PWM_MODE = 1 (PWM mode), CLAMP_HIGH = CLAMP_LOW = 0 (PWM duty cycle)	–	–	90	%D
		PWM_MODE = 0 (SENT mode)	–	–	4095	LSB

[1] 1 G (gauss) = 0.1 mT (millitesla).

[2] See Protection Features section.

[3] Determined by design.

[4] Clarity of a Read Acknowledge message from the device to the controller will be affected by the amount of capacitance and wire inductance on the device output. In such case, it is recommended to slow down the communication speed, and to lower the receiver threshold for reading digital Manchester signal.

[5] Parameter is verified by lab characterization with a limited amount of samples.

[6] See Definitions of Terms section.

MAGNETIC CHARACTERISTICS: Valid through full operating temperature range, T_A , and supply voltage, V_{CC} ,
 $C_{BYPASS} = 10 \text{ nF}$, unless otherwise specified

Characteristics	Symbol	Test Conditions	Min.	Typ.	Max.	Unit ^{[1][2]}
FACTORY PROGRAMMED DEVICE VALUES (Before Customer Programming) ^{[2][3]}, $V_{CC} = 5 \text{ V}$, $T_A = 25^\circ\text{C}$						
Magnetic Input Signal Range	B_{IN}	SENS_COARSE = 0	–	±500	–	G
Magnetic Input Signal Offset	$B_{INOFFSET}$	SIG_OFFSET = 0	–	0	–	%FSI
Output Sensitivity	Sens	SENS_COARSE = 0, SENS_MULT = 0	0.097	0.1	0.103	%FSO/G
Quiescent Output	$OUT_{(Q)}$	$B_{IN} = 0 \text{ G}$, $T_A = 25^\circ\text{C}$	49.4	50	50.5	%FSO
Output Clamp	$OUT_{CLP(H)}$	PWM_MODE = 0 (SENT mode)	–	4095	–	LSB
		PWM_MODE = 1 (PWM mode) (PWM duty cycle)	94.8	95	95.2	%D
	$OUT_{CLP(L)}$	PWM_MODE = 0 (SENT mode)	–	0	–	LSB
		PWM_MODE = 1 (PWM mode) (PWM duty cycle)	4.8	5	5.2	%D
Sensitivity Drift Over Temperature ^[4]	ΔSens	$T_A = -40^\circ\text{C}$ to 25°C	–	<±0.03	–	%/°C
		$T_A = 25^\circ\text{C}$ to 150°C	–	<±0.02	–	%/°C
Output Offset Drift Over Temperature ^[5]	$\Delta\text{OUT}_{(Q)}$	$T_A = -40^\circ\text{C}$ to 25°C	–	<±0.005	–	%/°C
		$T_A = 25^\circ\text{C}$ to 150°C	–	<±0.005	–	%/°C

^[1] 1 G (gauss) = 0.1 mT (millitesla).

^[2] FSO means Full Scale Output and FSI means Full Scale Input. See Definitions of Terms section.

^[3] Device performance is optimized for the input magnetic range of SENS_COARSE = 0 and input offset of SIG_OFFSET=0. If a different magnetic input range or signal offset is required, please see the tables in the section EEPROM Customer-Programmable Parameter Reference, near the end of this document.

^[4] Does not include drift over lifetime and package hysteresis.

^[5] Offset drifts with temperature changes will be altered from the factory programmed values if Magnetic Input Signal Range is changed. If changes in Magnetic Input Signal Range cannot be avoided because of application requirements, please contact Allegro for detailed information.

PROGRAMMABLE CHARACTERISTICS: Valid through full operating temperature range, T_A , and supply voltage, V_{CC} , $C_{BYPASS} = 10 \text{ nF}$, unless otherwise specified

Characteristics	Symbol	Test Conditions	Min.	Typ.	Max.	Unit [1]
INTERNAL BANDWIDTH PROGRAMMING [2]						
Bandwidth Programming Bits		BW	–	3	–	bit
Bandwidth Programming Range	BW	$T_A = 25^\circ\text{C}$; for programming values, see BW in EEPROM Structure section	188	–	3000	Hz
Bandwidth Post-Programming Tolerance	ΔBW	$T_A = 25^\circ\text{C}$, measured as a percentage of BW	–	± 5	–	%
FINE QUIESCENT OUTPUT [2]						
Fine Quiescent Output Programming Bits		QOUT_FINE	–	12	–	bit
Fine Quiescent Output Programming Range	QOUT_FINE	$T_A = 25^\circ\text{C}$, $B_{IN} = 0 \text{ G}$	–49	–	49	%FSO
Fine Quiescent Output Programming Step Size	Step _{QOUT_FINE}	$T_A = 25^\circ\text{C}$, $B_{IN} = 0 \text{ G}$	–	0.0244	–	%FSO
OUTPUT SENSITIVITY [2]						
Output Sensitivity	SENS_OUT	$T_A = 25^\circ\text{C}$	0.025	–	0.18	%FSO/G
Sensitivity Multiplier Programming Bits		SENS_MULT	–	12	–	bit
Sensitivity Multiplier Programming Range	SENS_MULT	$T_A = 25^\circ\text{C}$	0	–	2	–
Sensitivity Multiplier Programming Step Size	Step _{SENS_MULT}	$T_A = 25^\circ\text{C}$	–	0.00048	–	–
LINEARIZATION [2]						
Linearization Positions		$T_A = 25^\circ\text{C}$	–	33	–	data sampling point
Linearization Position Coefficient Bits	LINPOS_COEFF	LIN_x, programmed with output fitting method	–	12	–	bit
Output Polarity Bit		LIN_OUTPUT_INVERT	–	1	–	bit
Input Polarity Bit		LIN_INPUT_INVERT	–	1	–	bit
TEMPERATURE COMPENSATION (TC) [2]						
1 st Order Sensitivity TC Programming Bits		TC1_SENS_CLD, $T_A = -40^\circ\text{C}$	–	8	–	bit
		TC1_SENS_HOT, $T_A = 150^\circ\text{C}$	–	8	–	bit
Typical 1 st Order Sensitivity TC Programming Range [3]	TC1_SENS_CLD TC1_SENS_HOT		–98	–	+291	m%/°C
1 st Order Sensitivity TC Programming Step Size [3]	Step _{TC1SENS}		–	1.53	–	m%/°C
2 nd Order Sensitivity TC Programming Bits		TC2_SENS_CLD, $T_A = -40^\circ\text{C}$	–	9	–	bit
		TC2_SENS_HOT, $T_A = 150^\circ\text{C}$	–	9	–	bit

Continued on the next page...

PROGRAMMABLE CHARACTERISTICS (continued): Valid through full operating temperature range, T_A , and supply voltage, V_{CC} , $C_{BYPASS} = 10$ nF, unless otherwise specified

Characteristics	Symbol	Test Conditions	Min.	Typ.	Max.	Unit [1]
TEMPERATURE COMPENSATION (TC) [2] (continued)						
Typical 2 nd Order Sensitivity TC Programming Range [3][4]	TC2_SENS_CLD TC2_SENS_HOT		-1.53	-	1.53	m%/°C ²
2 nd Order Sensitivity TC Programming Step Size [3][4]	Step _{TC2SENS}		-	0.00596	-	m%/°C ²
1st Order Magnetic Offset TC Programming Bits		TC1_OFFSET	-	8	-	bit
Typical 1st Order Magnetic Offset TC Programming Range	TC1_OFFSET	SENS_COARSE = 0	-0.48	-	+0.48	G/°C
1st Order Magnetic Offset TC Step Size	Step _{TC1_OFFSET}		-	0.00381	-	G/°C
OUTPUT CLAMPING RANGE [2]						
Clamp Programming Bits		CLAMP_HIGH	-	6	-	bit
		CLAMP_LOW	-	6	-	bit
Output Clamp Programming Range	OUT _{CLP(H)}	$T_A = 25^\circ\text{C}, V_{CC} = 5\text{ V}$	50.78	-	100	%FSO
	OUT _{CLP(L)}	$T_A = 25^\circ\text{C}, V_{CC} = 5\text{ V}$	0	-	49.22	%FSO
Clamp Programming Step Size	Step _{CLP(H)}	$T_A = 25^\circ\text{C}$	-	0.78	-	%FSO
	Step _{CLP(L)}	$T_A = 25^\circ\text{C}$	-	0.78	-	%FSO
ACCURACY (After Customer Programming)						
Linearity Sensitivity Error	Lin _{ERR}		-	<±1	-	%
Sensitivity Drift Due to Package Hysteresis	ΔSens _{PKG}	Variation on final programmed Sensitivity value; measured at $T_A = 25^\circ\text{C}$ after temperature cycling from 25°C to 150°C and back to 25°C	-	< ±1	-	%
Sensitivity Drift Over Lifetime	ΔSens _{LIFE}	$T_A = 25^\circ\text{C}$, shift after AEC-Q100 grade 0 qualification testing	-	±3	-	%
Quiescent Output Drift over Lifetime	ΔOUT _{(Q)LIFE}	$T_A = 25^\circ\text{C}$, shift after AEC-Q100 grade 0 qualification testing	-	<±1	-	%
SENT CHARACTERISTICS [2]						
SENT Output Signal	V _{SENT(L)}	$10\text{ k}\Omega \leq R_{\text{pullup}} \leq 50\text{ k}\Omega$	-	-	0.05	V
	V _{SENT(H)}	Minimum $R_{\text{pullup}} = 10\text{ k}\Omega$	$0.9 \times V_{CC}$	-	-	V
		Maximum $R_{\text{pullup}} = 50\text{ k}\Omega$	$0.7 \times V_{CC}$	-	-	V
SENT Output Trigger Signal	V _{SENTtrig(L)}		-	-	1.2	V
	V _{SENTtrig(H)}		2.8	-	-	V

[1] 1 G (gauss) = 0.1 mT (millitesla).

[2] Determined by design.

[3] The unit m% = 0.001%; for example, 250 m%/°C = 0.025 %/°C = 2.5×10^{-3} /°C.

[4] The unit m%/C² means: $(10^{-3} \times \%) / \text{C}^2$.

CHARACTERISTIC PERFORMANCE

Average Supply Current (On) versus Supply Voltage

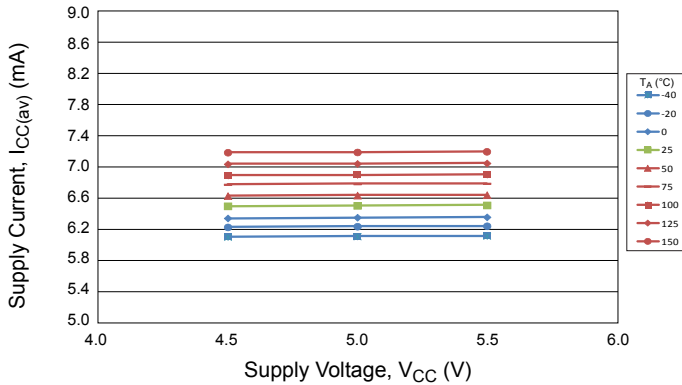

Average Supply Current (On) versus Temperature

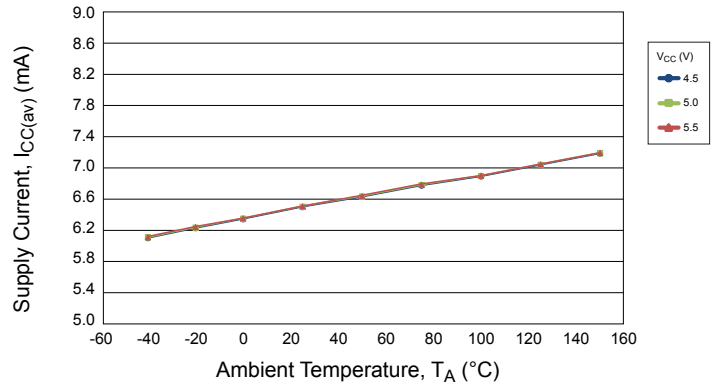

Output Saturation Voltage versus Average Supply Voltage

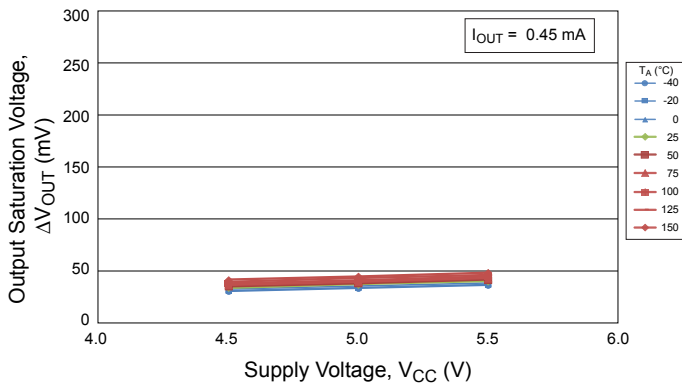

Output Saturation Voltage versus Average Temperature

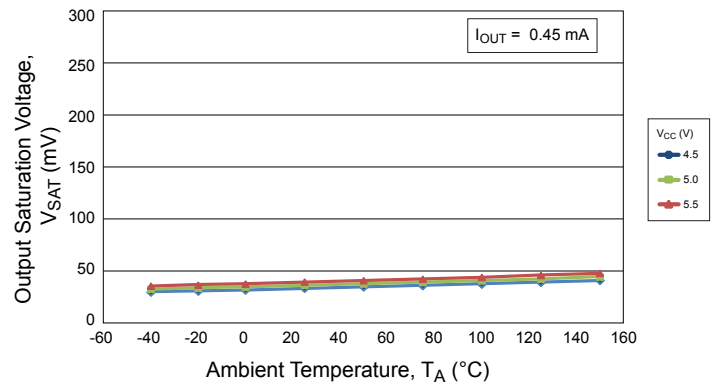

Lower Clamp versus Average Temperature

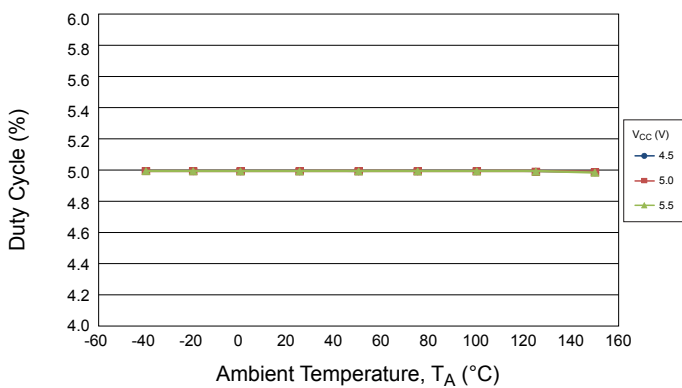

Upper Clamp versus Average Temperature

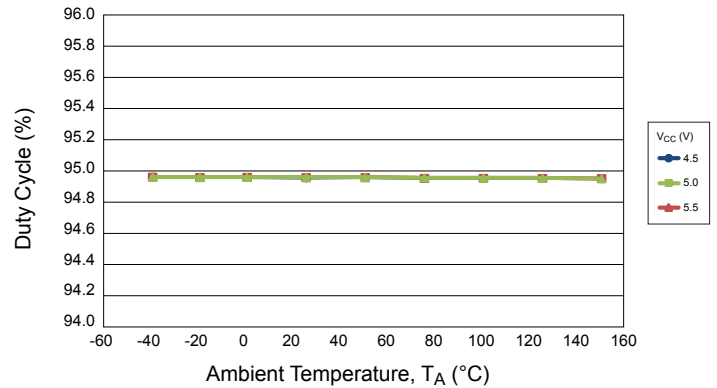

Factory Programmed Sensitivity Drift versus Ambient Temperature

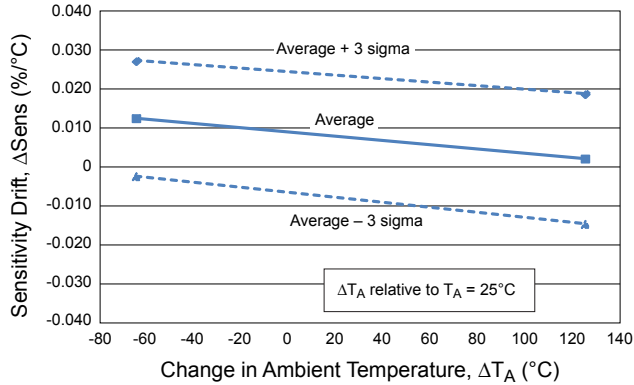

Factory Programmed Sensitivity versus Ambient Temperature

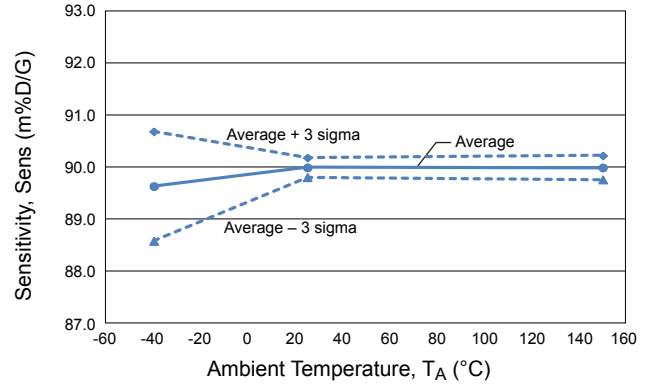

Factory Programmed Quiescent Voltage Output Drift versus Ambient Temperature

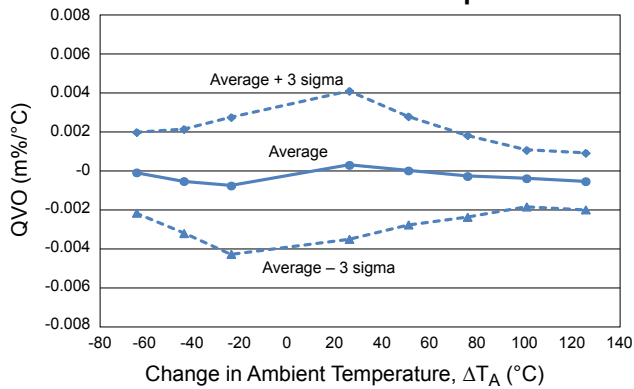

Factory Programmed Quiescent Voltage Output versus Ambient Temperature

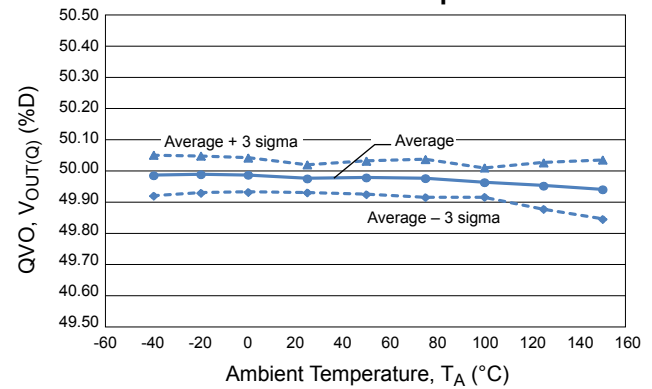

Positive Linearity versus Ambient Temperature

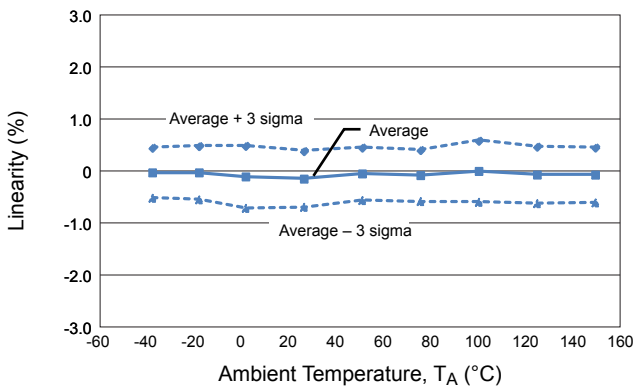

Negative Linearity versus Ambient Temperature

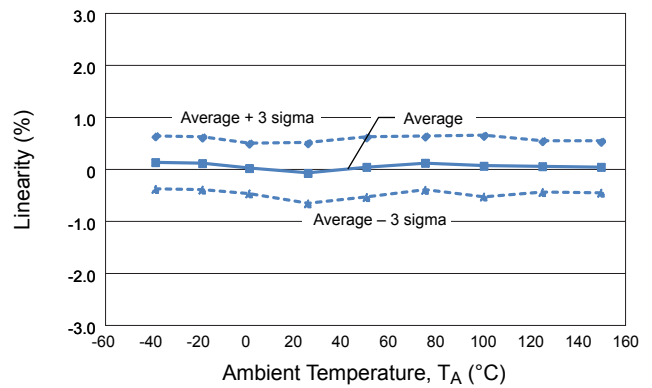

QOUT_FINE Step Size Duty Cycle versus Ambient Temperature

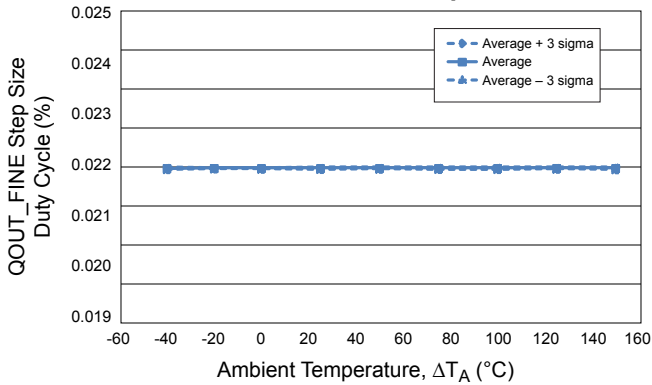

Quiescent Output Duty Cycle versus QOUT_FINE Code versus Ambient Temperature

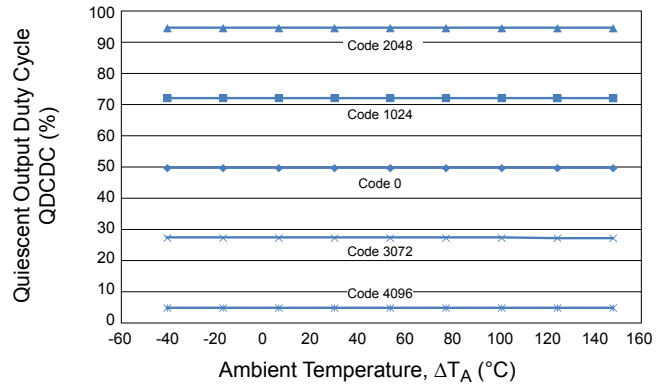

Clamp Step Size Duty Cycle versus Ambient Temperature

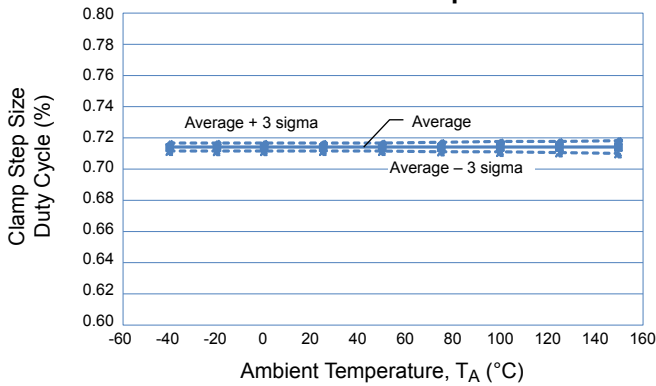

Quiescent Output Duty Cycle versus SENS_MULT Code versus Ambient Temperature

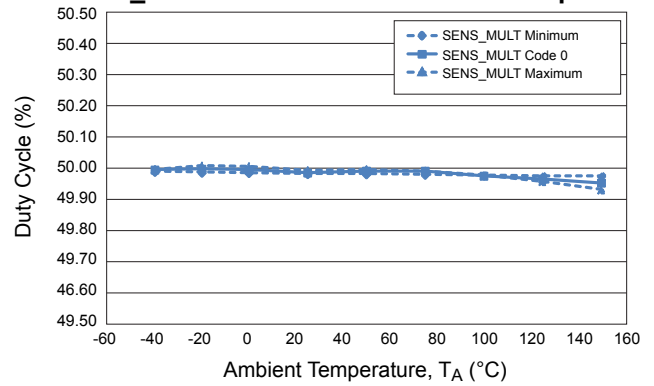

Sensitivity Multiplication Factor versus Ambient Temperature

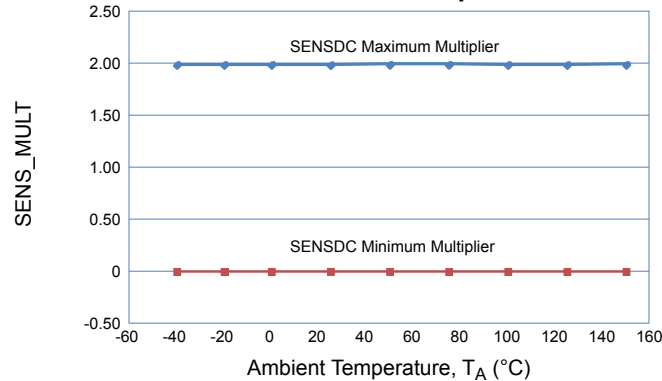

FUNCTIONAL DESCRIPTION

This section provides descriptions of the operating features and subsystems of the A1341. For more information on specific terms, refer to the Definitions of Terms section. Tables of EEPROM parameter values are provided in the EEPROM Structure section.

Signal Processing Parameter Setting

The A1341 has customer-programmable parameters that allow the user to optimize the signal processing performed by the A1341. Customer-programmable parameters apply to digital signal processing (DSP) stage. Programmed settings are stored in onboard EEPROM. The programming communication protocol is described in the Programming Serial Interface section.

The initial analog processing is factory programmed to match the application environment in terms of magnetic field range and offset. This allows optimization of the electrical signal presented to the DSP stage:

$$Y_{AD} (\%FSO) = SENS_COARSE (\%FSO/G) \times B_{IN} + SIG_OFFSET (\%FSI) + QOUT (\%FSO) \quad (1)$$

where:

Y_{AD} is the output of the analog subsystem to the A-to-D converter,

$SENS_COARSE$ is the factory-set coarse sensitivity,

B_{IN} is the current magnetic input signal,

SIG_OFFSET the factory-set signal offset, and

$QOUT$ is the quiescent voltage output with no factory compensation.

The DSP stage provides customer-programmable sensitivity (gain) fine offset adjusting, TC processing, bandwidth, clamp, and linearization selection.

Output is a digital voltage signal, proportional to the applied magnetic signal, with customer-selectable formatting: either pulse-wave modulated (PWM) or in the single edge nibble transmission encoding scheme (SENT). The Full Scale Output range is proportional to the Full Scale Input range, but is optimized by customer-programmed parameters.

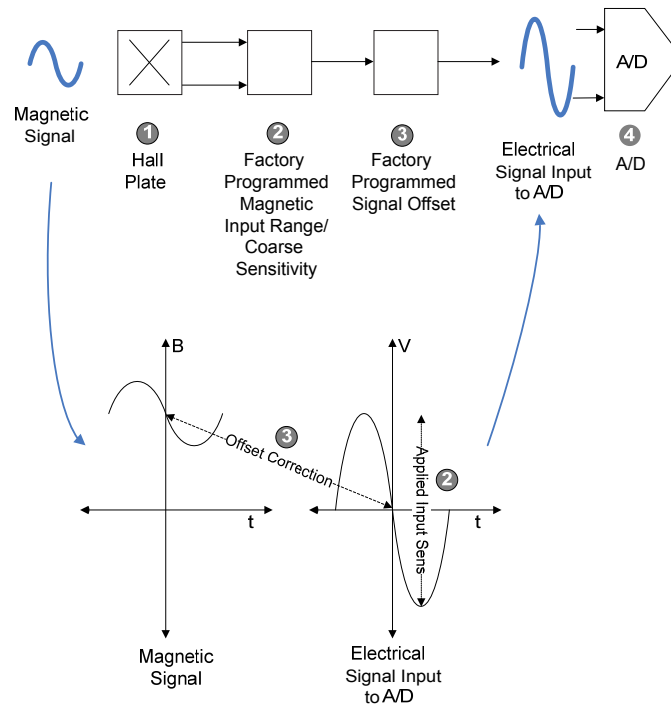

Figure 2: Signal Path for Analog Subsystem

Digital Signal Processing

The digitized analog signal is digitally processed to optimize accuracy and resolution for conversion to the device output stage. An advanced linearization feature also is available.

BANDWIDTH SELECTION

The 3-dB bandwidth, BW , determines the frequency at which the DSP function imports data from the analog front end A-to-D convertor. It is programmed by setting the BW parameter in EEPROM. The values chosen for BW and $RANGE$ affect the DSP stage output resolution and the Signal Response Time, t_{RESP} . These tradeoffs are represented in the Electrical Characteristics table, above.

TEMPERATURE COMPENSATION

The magnetic properties of materials can be affected by changes in temperature, even within the rated ambient operating temperature range, T_A . Any change in the magnetic circuit due to temperature variation causes a proportional change in the device output.

The device can be compensated internally using the Temperature Compensation (TC) circuitry. TC coefficients can be programmed for Sensitivity and magnetic offset. The effect of temperature is referred to as *drift*.

For magnetic offset, compensation for 1st Order Magnetic Offset TC, $TC1_OFFSET$, is a linear algorithm accounting for effects of ambient temperature changes during device operation (see Figure 4). It can be programmed using the $TC1_OFFSET$ parameter

Table 1: Bandwidth-Related Tradeoffs

Bandwidth Selection [Internal Update Rate] (kHz)	DSP Output Resolution (bit)
Other	11 to 12
3.000 [16.0]	10 to 11

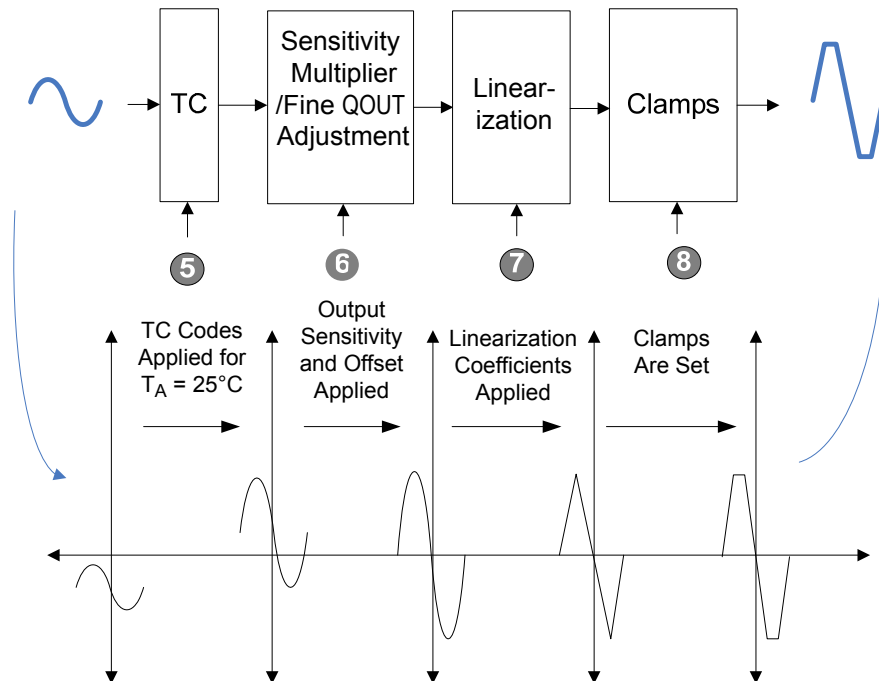

Figure 3: Signal path for digital subsystem

in a range of $\pm 0.48 \text{ G/}^\circ\text{C}$. This compensation is applied in DSP, after bandwidth selection.

Sensitivity drift compensation is customer-programmed (described below), within a framework of programmed temperature compensation. Optional temperature compensation for Sensitivity can be applied using built-in first-order and second-order algorithms. Both approaches adjust the device gain in response to input signal drift by adding or subtracting a value. The coefficients are programmed separately for temperatures above 25°C and below 25°C , as shown in Table 2. The resulting functions are illustrated in Figure 5.

Either first-order or second-order, or both TC algorithms can be applied. To apply an algorithm, select non-zero coefficients for the corresponding EEPROM parameters (TC1_SENS_CLD and TC1_SENS_HOT for first-order, TC2_SENS_CLD and TC2_SENS_HOT for second order). If a method should not be used, set the corresponding EEPROM parameter values to zero. If both are selected, the A1341 applies the first-order, and then the second-order algorithm during this stage.

The programmed values set the temperature compensation, Y_{TC} , according to the following formula:

$$Y_{TC} (\%FSO) = Y_{AD} (\%FSO) + [(TC1_SENS (m\%/^\circ\text{C}) \times \Delta T_A (^\circ\text{C})) + (TC2_SENS (m\%/^\circ\text{C}^2) \times \Delta T_A^2 (^\circ\text{C}^2))] \times (Y_{AD} (\%FSO) - SIG_OFFSET (\%FSI)) + TC1_OFFSET (G/^\circ\text{C}) \times 0.09 (\%FSO/G) \times SENS_COARSE_COEF \times \Delta T_A (^\circ\text{C}) \quad (2)$$

where:

Y_{AD} is the input from the analog subsystem via the A-to-D converter,

TC1_SENS is the first-order coefficient: either TC1_SENS_HOT or TC1_SENS_CLD depending on T_A ,

TC2_SENS is the second-order coefficient: either TC2_SENS_HOT or TC2_SENS_CLD depending on T_A ,

ΔT_A is the change in ambient temperature from 25°C (for example: at 150°C , $\Delta T_A = 150^\circ\text{C} - 25^\circ\text{C} = 125^\circ\text{C}$, or at -40°C , $\Delta T_A = -40^\circ\text{C} - 25^\circ\text{C} = -65^\circ\text{C}$),

SIG_OFFSET (set to 0) is the factory programmed addition to the magnetic offset parameter (sets the centerpoint of Y_{AD}), and

$SENS_COARSE_COEF = SENS_COARSE_{(code\ 0)}/SENS_COARSE_{(factory\ code)}$ (sets the factory-programmed sensitivity of the Y_{AD} function).

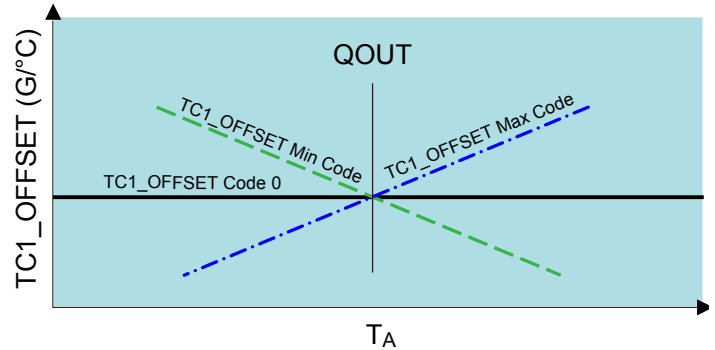

Figure 4: The 1st Order Magnetic Offset Temperature Compensation Coefficient (TC1_OFFSET) is used for linear adjustment of device output for temperature changes.

Table 2: Sensitivity Temperature Compensation options

	T_A Range	
	$< 25^\circ\text{C}$	$> 25^\circ\text{C}$
1st Order	TC1_SENS_CLD	TC1_SENS_HOT
2nd Order	TC2_SENS_CLD	TC2_SENS_HOT

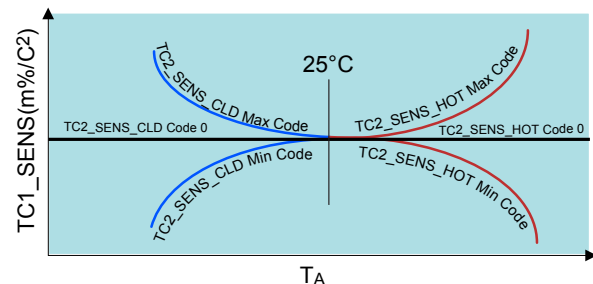
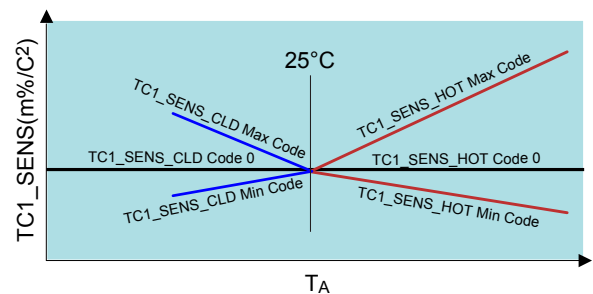

Figure 5: Sensitivity TC Functions (upper) first order, (lower) second order

SENSITIVITY (GAIN) ADJUSTMENT

Sensitivity is applied in the DSP subsystem, after bandwidth selection and temperature compensation. Note: If Sensitivity must be adjusted more than 20% from the nominal value, please consider switching input magnetic range for the optimization of A-to-D input.

OUTPUT FINE OFFSET ADJUSTMENT

The Fine Offset adjustment is the segment of the DSP signal used to trim the device output, OUT (%FSO).

$QOUT_FINE$ is a customer-programmable parameter that sets the Quiescent Output, $QOUT$, which is device output when there is no significant applied magnetic field. The programmed value sets the DSP output, Y_{DA} , taking into account the selected Sensitivity:

$$Y_{DA} (\%FSO) = SENS_MULT \times Y_{TC} (\%FSO) + QOUT_FINE (\%FSO) \quad (3)$$

$$SENS_OUT (\%FSO/G) = SENS_MULT \times SENS (\%FSO/G) \quad (4)$$

where $SENS_MULT$ is the multiplication factor from 0 to 2.

$QOUT_FINE$ is set as a percentage of OUT . It can be set to add up to 50% of FSO to the output of the DSP stage, or subtract up to 50% of FSO from the DSP output.

LINEARIZATION OF OUTPUT

Magnetic fields are not always linear throughout the full range of target positions, such as in the case of ring magnet targets rotated in front of a non-back-biased linear Hall sensor IC, shown in Figure 6. The A1341 provides a programmable linearization feature that allows adjustment of the transfer characteristic of the device so that, as the actual position of the target changes, the resulting changes in the applied magnetic field can be output as corresponding linear increments.

In order to achieve this, an initial set of linearization coefficients has to be created. The user takes 33 samples of B_{IN} : at the start and at every 1/32 interval of the full input range. The user then enters these 33 values into the Allegro ASEK programming utility for the A1341, or an equivalent customer software program, and generates coefficients corresponding to the values. The user then uses the software load function to transmit the coefficients to the EEPROM ($LINPOS_COEFF$ parameter). The user then sets the LIN_TABLE_DONE parameter to 1. When the A1341 is in operation, it applies a built-in algorithm to linearize output based on the stored coefficients.

Each of the coefficient values can be individually overwritten during normal operation. Figure 7 shows an example input-output curve. The y axis represents the 32 equal full scale position segments, and the x axis represents the the range of movement. When the A1341 is in operation, it applies a linearization curve built from the 33 coefficients provided by the user. For example,

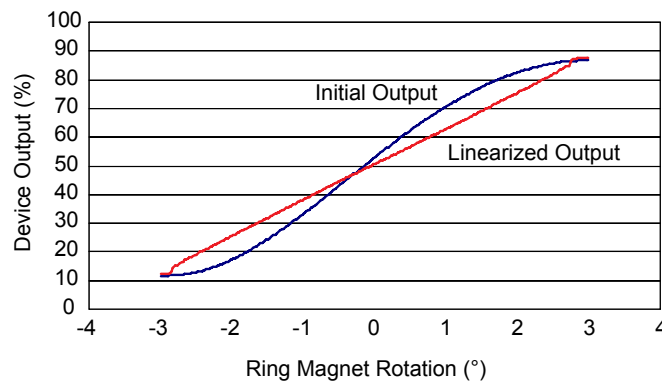

Figure 6: Example of Linearization of a Sinusoidal Magnetic Signal Generated by a Rotating Ring Magnet

at position 5 the device originally would output 384 LSB of magnetic field. This 384 LSB is treated as input to the inverse linearization function, after rescaling to the x axis as follows:

$$(384 - 128(\text{offset})) \times [32 / (3968(\text{LSBmax}) - 128(\text{LSBmin}))] + 1 = 3.2$$

For $x = 3.2$, the inverse function will give output of 570 LSB which is right on the curve of the linear output signal.

OUTPUT POLARITY

Device Output Polarity can be changed using the LIN_OUTPUT_INVERT bit set to 1. If the goal is to change output polarity and apply linearization, the output polarity should be changed by setting the gain of the linearization function to 1 (linearization table coefficients are decimal values from 0 to 4096 with steps of 128 codes) and setting the LIN_INPUT_INVERT bit to 1. Then user can collect 33 points for linearization and

calculate the coefficients. After the coefficients are loaded into the device, successful linearization will be applied by leaving the LIN_INPUT_INVERT bit set to 1 and setting the LIN_TABLE_DONE bit to 1.

OUTPUT CLAMPS SETTING

To eliminate the effects of outlier points, the A1341 Clamp Range, OUT_{CLP} , is initially set to 100% of FSO for high clamp and 0% of FSO for low clamp, and can be adjusted using the CLAMP_HIGH and CLAMP_LOW parameters.

OUTPUT PROTOCOL SELECTION

The A1341 supports a linear voltage output in either PWM or SENT format. The PWM_MODE parameter in EEPROM sets the format. (Output format programming is described in the Linear Output Protocols section.)

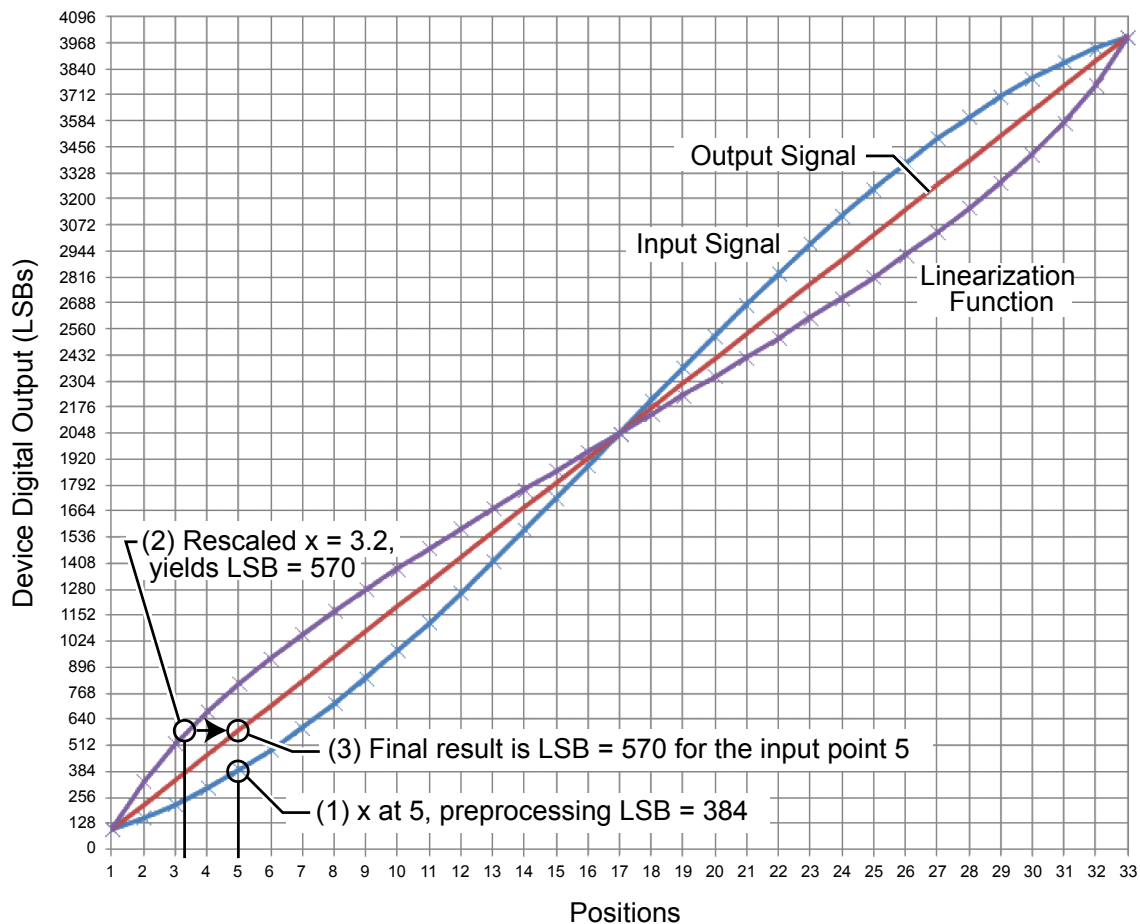

Figure 7: Sample of Linearization Function Transfer Characteristic.

Protection Features

Lockout and clamping features protect the A1341 internal circuitry and prevent spurious output when supply voltage is out of specification. Open circuit detection is also provided.

OPERATING VOLTAGE AND LOW VOLTAGE DETECTION

Supply voltage detection features protect the A1341 internal circuitry and prevent spurious output when V_{CC} is out of specification. Diagnostic circuitry reuses the output pin (OUT) to provide feedback to the external controller. The A1341 provides protection for both overvoltage and undervoltage on the supply line. The A1341 has two active circuits to identify when the supply voltage is below the minimum operating level. The internal power-on reset circuitry, POR, controls when an internal reset is triggered. If the supply voltage drops below POR_{LOW} , an internal reset occurs and the output is forced to a high impedance state. When the supply voltage rises above POR_{HIGH} , the device comes out of reset and the output response is dependent on the Low Voltage Detection feature.

The Low Voltage Detection, LVD, feature provides feedback to the external controller when V_{CC} is below minimum operating level, but above the POR threshold. This feature is enabled by default and is disabled by setting LVD_DIS to logic 1. When configured for SENT output, if the supply voltage drops below $V_{CC(LVD)LOW}$, a status bit is set in the SENT message to indicate a low supply voltage condition. When configured for PWM output, if the supply voltage drops below $V_{CC(LVD)LOW}$, the output is forced to a Logic low state. As the supply voltage rises above $V_{CC(LVD)HIGH}$, the output returns to normal operating state.

The Overvoltage Lockout Threshold, $V_{CC(OV)}$, is customer programmable to either 6.5 or 19.3 V typical, by setting the $OVLO_LO$ parameter. By default, the part will produce an error at the output if $V_{CC} > 19.3$ V. Setting $OVLO_LO = 1$ changes this condition to $V_{CC} > 6.5$ V. When $OVLO_LO = 1$, using programming pulses higher than V_{CC} will cause the part to enter in and out of overvoltage lockout mode, causing intermittent errors at the output. This behavior is not fatal, but the output is not valid. If overvoltage conditions are reached, the PWM output will be brought to GND or the $SENT_STATUS$ bits will be set to indicate the condition.

OPEN CIRCUIT DETECTION

Diagnostic circuitry reuses the output pin (OUT) to provide feedback to the external controller. A sense resistor, R_{OCD} , can be placed between OUT and a separate V_{BAT} reference, as shown in Table 3.

Typical Application

Multiple A1341 linear devices can be connected to the external controller as shown in Figure 8. However, EEPROM programming in the A1341 occurs when the external control unit excites the A1341 OUT pin by EEPROM pulses generated by the ECU. Whichever A1341s are excited by EEPROM pulses on their OUT pin will accept commands from the controller.

Table 3: Open Circuit Diagnostic Truth Table

	Node A	Node B	Node C	OUT State
V_{BAT} Referenced				
	Open	Closed	Closed	0 V to V_{BAT}
	Closed	Open	Closed	GND/Float
	Open	Open	Closed	GND/Float
	Open	Closed	Open	V_{BAT}
	Closed	Open	Open	V_{CC}
	Closed	Closed	Open	V_{CC} to V_{BAT}

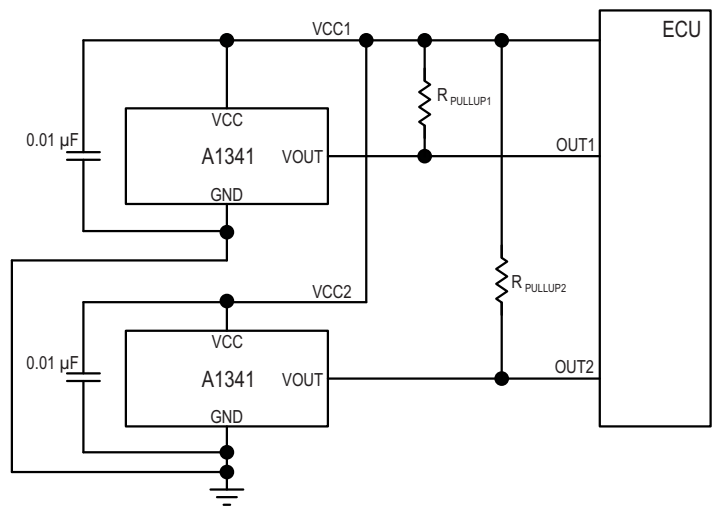

Figure 8: Typical Application

EEPROM Lock Features

MEMORY LOCKING MECHANISMS

The A1341 is equipped with two distinct memory locking mechanisms:

Default Lock

At power up, all registers of the A1341 are locked by default. EEPROM and volatile memory cannot be read or written. To disable Default Lock, a very specific 30-bit customer access code is written to address 0x24 in less than 70 ms from power-up; see Write Access code. After this, device registers are accessible through the programming interface. If V_{CC} is power cycled, the

Default Lock automatically reenables. This ensures that during normal operation, memory content will not be altered due to unwanted glitches on V_{CC} or the output pin.

Lock Bit

This is used after EEPROM parameters are programmed by the customer. The customer programmable EELOCK feature disables the ability to write to any EEPROM register. This feature takes effect after writing the EELOCK bit and resetting power to the device. This prevents the ability to disable Default Lock using the method described above. Please note that after EELOCK bit is set and V_{CC} pin power cycled, the customer will not have the ability to clear the EELOCK bit or to write any register. Customer will still have ability to read any EEPROM register.

PROGRAMMING SERIAL INTERFACE

The A1341 incorporates a serial interface that allows an external controller to read and write registers in the A1341 EEPROM and volatile memory. The A1341 uses a point-to-point communication protocol, based on Manchester encoding per G. E. Thomas (a rising edge indicates 0 and a falling edge indicates 1), with address and data transmitted MSB first.

Transaction Types

Each transaction is initiated by a command from the controller; the A1341 does not initiate any transactions. Two commands are recognized by the A1341: Write and Read. There also are three special function Write commands: Write Access Code, Write Disable Output, and Write Enable Output. One response frame type is generated by the A1341, Read Acknowledge.

If the command is Read, the A1341 responds by transmitting the requested data in a Read Acknowledge frame. If the command is any other type, the A1341 does not acknowledge.

As shown in Figure 9, The A1341 receives all commands via the VCC pin. It responds to Read commands via the OUT pin. This implementation of Manchester encoding requires the communication pulses be within a high ($V_{MAN(H)}$) and low ($V_{MAN(L)}$)

range of voltages for the VCC line and the OUT line. The Write command pulses to EEPROM are supported by two high voltage pulses on the OUT line.

Writing the Access Code

If the external controller will write to or read from the A1341 memory during the current session, it must establish serial communication with the A1341 by sending a Write command including the Access Code within 70 ms after powering up the A1341. If this deadline is missed, all write and read access is disabled until the next power-up.

Writing to EEPROM

When a Write command requires writing to non-volatile EEPROM (all standard Writes), after the Write command the controller must also send two *Programming pulses*, well-separated, long high-voltage strobcs via the OUT pin. These strobcs are detected internally, allowing the A1341 to boost the voltage on the EEPROM gates.

The required sequence is shown in Figure 10.

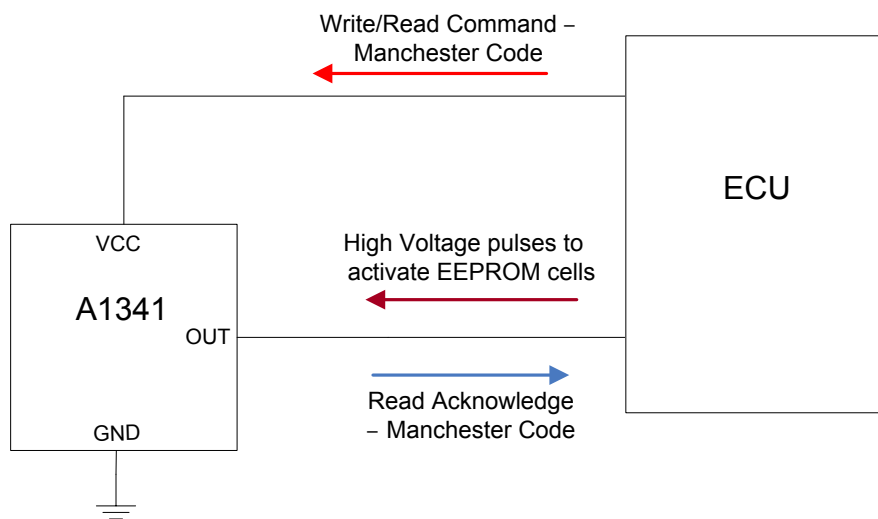

Figure 9: Top-level Programming Interface

Reading from EEPROM

A Read command with the register number is sent from the controller to the A1341. The device responds with a Read Acknowledge frame. Output is automatically disabled after the Read command from the controller is received and output is enabled after a Read Acknowledge command is sent.

Error Checking

The serial interface uses a cyclic redundancy check (CRC) for data-bit error checking (synchronization bits are ignored during the check).

The CRC algorithm is based on the polynomial

$$g(x) = x^3 + x + 1$$

and the calculation is represented graphically in Figure 11.

The trailing 3 bits of a message frame comprise the CRC token.

The CRC is initialized at 111.

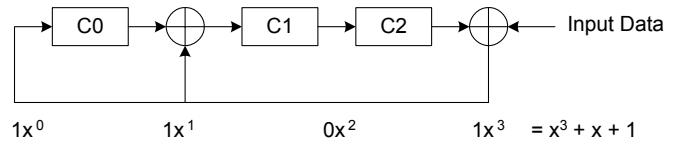

Figure 11: CRC Calculation

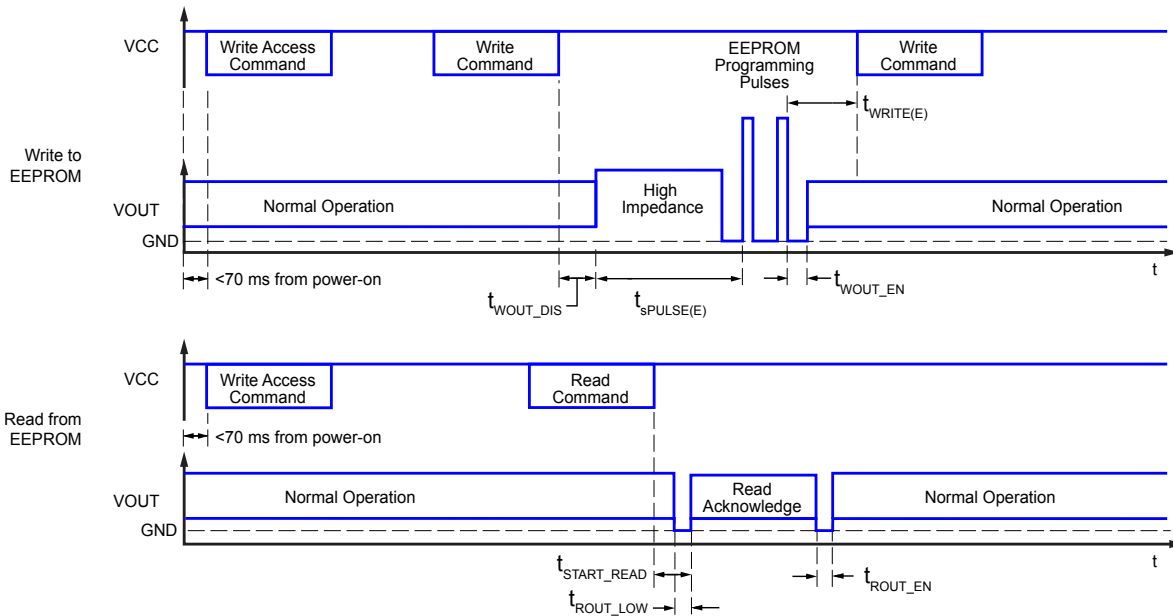

Figure 10: Programming Read and Write Timing Diagrams
(see Serial Interface Reference section for definitions)

Serial Interface Reference

Table 4. Serial Interface Protocol Characteristics [1]

Characteristics	Symbol	Note	Min.	Typ.	Max.	Unit
INPUT/OUTPUT SIGNAL TIMING						
Access Code Time Out	t_{acc}	Customer Access Code should be fully entered in less than t_{ACC} , measured from when V_{CC} crosses $V_{CC(UV_high)}$.	–	–	70	ms
Bit Rate		Defined by the input message bit rate sent from the external controller	4	–	100	kbps
Bit Time	t_{BIT}	Data bit pulse width at 4 kbps	243	250	257	μ s
		Data bit pulse width at 100 kbps	9.5	10	10.5	μ s
Bit Time Error	err_{TBIT}	Deviation in t_{BIT} during one command frame	–11	–	+11	%
Write Output Disable Delay	t_{WOUT_DIS}	Required delay from the trailing edge of certain Write command frames to output entering the high impedance state	–	9μ s – $0.25 \times t_{BIT}$	60	μ s
Write Delay	$t_{WRITE(E)}$	Required delay from the trailing edge of the second EEPROM Programming pulse to the leading edge of a following command frame	$2 \times t_{BIT}$	–	–	μ s
Write Output Enable Delay	t_{WOUT_EN}	Delay from the trailing edge of the final EEPROM programming pulse to output entering the normal operation state	–	6	60	μ s
Read Acknowledge Delay	t_{READ}	Required delay from the trailing edge of a Read Acknowledge frame to the leading edge of a following command frame	$2 \times t_{BIT}$	–	–	μ s
Read Output Disable Delay	t_{ROUT_LOW}	Time the output is pulled low by device before Read Acknowledge message	–	45	60	μ s
Read Delay [2]	t_{START_READ}	Delay from the trailing edge of a Read command frame to the leading edge of the Read Acknowledge frame	25μ s – $0.25 \times t_{BIT}$	50μ s – $0.25 \times t_{BIT}$	150μ s – $0.25 \times t_{BIT}$	μ s
Read Output Enable Delay	t_{ROUT_EN}	Required delay from the trailing edge of the final Read Acknowledge pulse to output entering the normal operation state	–	45	60	μ s
Disable Output Delay [2]	t_{DIS_OUT}	Delay from the trailing edge of a Disable Output command frame to the device output going from normal operation to the high impedance state	1μ s – $0.25 \times t_{BIT}$	5μ s – $0.25 \times t_{BIT}$	15μ s – $0.25 \times t_{BIT}$	μ s
Enable Output Delay [2]	t_{ENB_OUT}	Delay from the trailing edge of an Enable Output command frame to the device output going from the high impedance state to normal operation	1μ s – $0.25 \times t_{BIT}$	5μ s – $0.25 \times t_{BIT}$	15μ s – $0.25 \times t_{BIT}$	μ s
EEPROM PROGRAMMING PULSE						
EEPROM Programming Pulse Setup Time	$t_{SPULSE(E)}$	Delay from last edge of write command to start of EEPROM programming pulse	40	–	–	μ s
INPUT/OUTPUT SIGNAL VOLTAGE						
Manchester Code High Voltage	$V_{MAN(H)}$	Applied to VCC line	7.3	–	–	V
		Read from OUT line	$V_{CC} - 0.2$	–	–	V
Manchester Code Low Voltage	$V_{MAN(L)}$	Applied to VCC line	–	–	5.7	V
		Read from OUT line	–	–	V_{SAT}	V

[1] Determined by design.

[2] In the case where a slower baud rate is used, the output responds before the transfer of the last bit in the command message is completed.

Serial Interface Message Structure

The general format of a command message frame is shown in Figure 12. Note that, in the Manchester coding used, a bit value of 1 is indicated by a falling edge within the bit boundary, and a bit value of zero is indicated by a rising edge within the bit boundary.

The bits are described in Table 5.

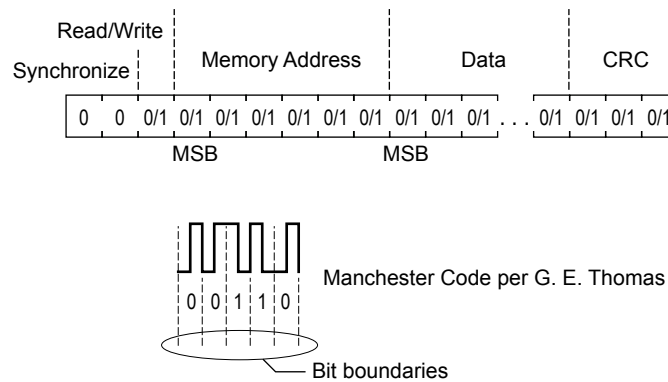

Figure 12: General Format for Serial Interface Commands

Table 5: Serial Interface Command General Format

Bits	Parameter Name	Values	Description
2	Synchronization	00	Used to identify the beginning of a serial interface command
1	Read/Write	0	[As required] Write operation
		1	[As required] Read operation
6	Address	0/1	[Read/Write] Register address (volatile memory or EEPROM)
Variable	Data	0/1	[As required] variable length, for data
3	CRC	0/1	Incorrect value indicates errors

The following command messages can be exchanged between the device and the external controller:

- Read
- Read Acknowledge
- Write
- Write Access Code
- Write Disable Output
- Write Enable Output

For EEPROM address information, refer to the EEPROM Structure section.

Table 6: Read

Function	Provides the address in A1341 memory to be accessed to transmit the contents to the external controller in the next Read Acknowledge command. A timely Write Access Code command is required once, at power-up of the A1341.
Syntax	Sent by the external controller on the A1341 VCC pin.
Related Commands	Read Acknowledge
Pulse Sequence	<div style="text-align: center;"> <p style="text-align: center;"> Read/Write Synchronize Memory Address CRC 0 0 1 0/1 0/1 0/1 0/1 0/1 0/1 0/1 0/1 0/1 0/1 MSB </p> </div>
Options	None
Examples	Address in non-volatile memory: 0XXXXXX Address in volatile memory: 100100 (Register 0x24)

Table 7: Read Acknowledge

Function	Transmits to the external controller data retrieved from the A1341 memory in response to the most recent Read command.
Syntax	Sent by the A1341 on the A1341 OUT pin. Sent after a Read command.
Related Commands	Read
Pulse Sequence	<p>The diagram shows a bit stream: 0 0 0/1 0/1 0/1 0/1 ... 0/1 0/1 0/1 0/1 0/1. Vertical dashed lines separate the 'Synchronize' (0 0) section, the 'Data (30 bits)' section, and the 'CRC' section. The first six bits of the data section are grouped and labeled 'MSB'.</p>
Options	If EEPROM Error Checking and Correction (ECC) is not disabled by factory programming, the 6 MSBs are EEPROM data error checking bits. Refer to the EEPROM Structure section for more information.
Examples	–

Table 8: Write

Function	Transmits to the A1341 data prepared by the external controller.
Syntax	Sent by the external controller on the A1341 VCC pin. A timely Write Access Code command is required once, at power-up of the A1341. For writing to non-volatile memory.
Related Commands	Disable Output, Enable Output, Write Access Code
Pulse Sequence	<p>The diagram shows a bit stream: 0 0 0 0/1 0/1 0/1 0/1 0/1 0/1 0/1 0/1 0/1 ... 0/1 0/1 0/1 0/1. Vertical dashed lines separate the 'Read/Write' (0 0 0) section, the 'Memory Address' section, the 'Data (30 bits)' section, and the 'CRC' section. The first six bits of the address section and the first six bits of the data section are each labeled 'MSB'.</p>
Options	–
Examples	Address in non-volatile memory: 0XXXXX Address in volatile memory: 100100 (Register 0x24)

Table 9: Write Access Code

Function	Transmits the Access Code to the A1341; data prepared by the external controller, but must match the internal 30-bit code in the A1341 memory.
Syntax	Sent by the external controller on the A1341 VCC pin. Sent within 70 ms of A1341 power-on, and before any other command.
Related Commands	
Pulse Sequence	
Options	None
Examples	Standard Customer Access Code: 0x2781_1F77 to address 0x24

Table 10: Write Disable Output

Function	Places OUT in a high impedance state. It is not required, but it can be used to disable normal output for longer time than the time that device applies to disable the output after a Read command from the controller.
Syntax	Sent by the external controller on the A1341 VCC pin. For writing to non-volatile memory.
Related Commands	Write Enable Output
Pulse Sequence	
Options	None
Examples	0x10 to address 0x24

Table 11: Write Enable Output

Function	Restores normal output from the OUT pin after a high impedance state has been imposed by a Disable Output command.
Syntax	Sent by the external controller on the A1341 VCC pin. For writing to non-volatile memory: Sent after a Write command and corresponding EEPROM Programming pulses. For reading: Sent after a Read Acknowledge command.
Related Commands	Write Disable Output
Pulse Sequence	
Options	None
Examples	0x0 to address 0x24

LINEAR OUTPUT PROTOCOLS

The operating output of the A1341 is digital voltage signal that transfers information proportionally to the applied magnetic input signal. Two customer-selectable options are provided for output signal formatting: pulse-wave modulated (PWM), and single edge nibble transmission encoding scheme (SENT, SAEJ2716).

PWM Output Mode

PWM involves converting the output voltage amplitude to a series of constant-frequency binary pulses, with the percentage of the of high portion of the pulse varied in direct proportion to the

direct proportion to the applied magnetic field.

The PWM output mode is configured by setting the following parameters in EEPROM:

- PWM_MODE set to 1 to select the PWM option (for programming parameters, see EEPROM Structure section)
- FPWM sets the PWM carrier frequency
- CALIBRATE_PWM parameter can be set to enable calibration of the output 50% duty cycle level at power-on

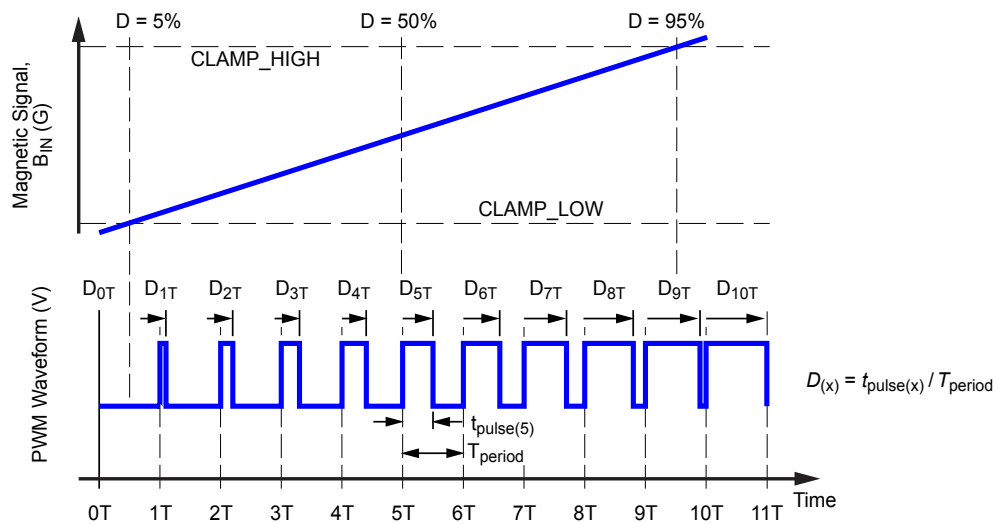

Figure 13: PWM Mode

SENT Output Mode

The SENT output mode converts the input magnetic signal to a binary value mapped to the Full Scale Output, FSO, range of 0 to 4095, shown in Figure 14. This data is inserted into a binary pulse message, referred to as a *frame*, that conforms to the SENT data transmission specification (SAEJ2716 JAN2010). Certain parameters for configuration of the SENT messages can be set in EEPROM.

The SENT output mode is configured by setting the following parameters in EEPROM:

- PWM_MODE set to 0 (default) to select the SENT option
- SENT_x programming parameters (see EEPROM Structure section)

MESSAGE STRUCTURE

A SENT message is a series of *nibbles*, with the following characteristics:

- Each nibble is an ordered pair of a low-voltage interval followed by a high-voltage interval
- Either interval can be the *delimiting state*, which only sets a

boundary for the nibble; to assign the delimiting state, select a fixed duration for the interval (the SENT_LOVAR parameter selects the interval, and SENT_FIXED sets the duration)

- The other interval in the pair becomes the *information state* and is variable in duration in order to contain the data payload of the nibble

The duration of a nibble is denominated in clock *ticks*. The period of a tick is set by dividing a 4-MHz clock by the value of the SENT_TICK parameter. The duration of the nibble is the sum of the low-voltage interval plus the high-voltage interval.

The nibbles of a SENT message are arranged in the following required sequence (see Figure 15):

1. Synchronization and Calibration: flags the start of the SENT message
2. Status and Communication: provides A1341 status and the format of the data
3. Data: magnetic field and optional data
4. CRC: error checking
5. Pause Pulse (optional): sets timing relative to A1341 updates

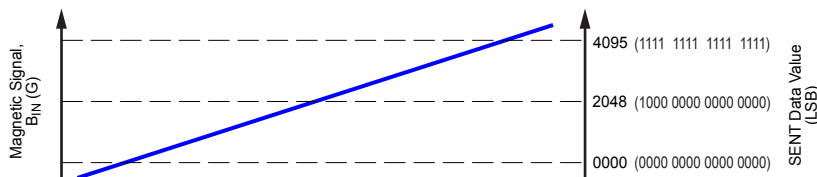

Figure 14: SENT Mode Outputs a Digital Value that can be Read by the External Controller

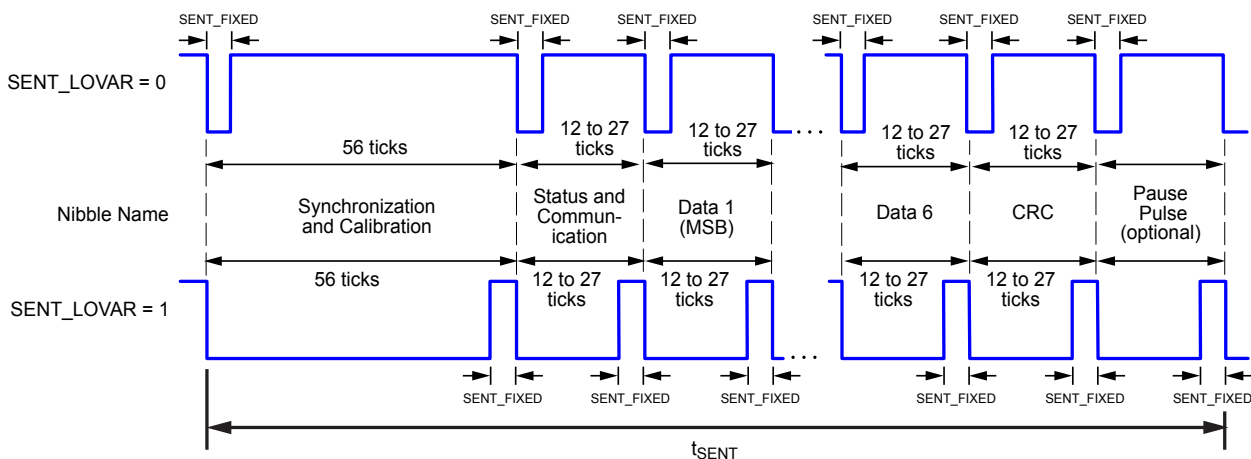

Figure 15: General Format for SENT Message Frame
(upper panel) low state fixed, (lower panel) high state fixed

OPTIONAL SERIAL OUTPUT PROTOCOL

In the Status and Communication section, the data format selection can be:

- Normal device output (voltage proportional to applied magnetic field) in SENT protocol (SENT_SERIAL = 0).
- Augmented data on the magnetic parameters and device settings, in an optional Serial Output protocol (SENT_SERIAL = 1, 2, or 3). Any of these three protocols enables transmission of values from the following EEPROM parameters, in the following order:

Table 12: Serial Output Protocols

Message ID (4 or 8 bits)	Data (8, 12, or 16 bits)
0	Corrected temperature
1	SENS_COARSE
1	SIG_OFFSET
3	QOUT_FINE
4	SENS_MULT
5	CLAMP_HIGH
6	CLAMP_LOW
7	DEVICE_ID (always 1341 ₁₀)

- Additional Short serial protocol (SENT_SERIAL = 1). Has a message payload of 12 bits: 8 bits are for value data, and 4 bits for the message ID (identification). A total of 16 separate SENT messages are required to transmit the entire data group.
- Additional Enhanced 16-bit serial protocol (SENT_SERIAL = 2). Has 12 bits for value data, and 4 bits for the message ID. A total of 18 SENT messages are required to transmit the entire data group.
- Additional Enhanced 24-bit serial protocol (SENT_SERIAL = 3). Has 16 bits for value data, and 8 bits for the message ID. A total of 18 SENT messages are required to transmit the entire data group.

DATA NIBBLE FORMAT

When transmitting normal operation data, information about the magnetic field is embedded in the first three Data nibbles. Each Data nibble consists of 4 bits with values ranging from 0 to 15. In order to present an output with the resolution of 12 bits, 3 Data nibbles are required. The Data nibble containing the MSB of the whole Data section is sent first.

Three additional optional Data nibbles can be associated with other parameters, by setting the parameter SENT_DATA:

- Counter – Each message frame has a serial number in each Counter nibble
- Temperature – Temperature data from the A1341 internal temperature sensor, in two's complement format, with MSB first:
 - All zeros = 25°C
 - Always is 0.8 LSB/°C except for serial output protocol
 - For serial output protocol, temperature slope = 0.5 LSB/°C.
- Inverted – The last nibble in the message frame is the first nibble, inverted (as an additional error check)

PAUSE PULSE TIMING SYNCHRONIZATION

In the Pause Pulse section, additional time can be added at the end of a SENT message frame to ensure all message frames are of equal length. The SENT_UPDATE parameter selects one of these options:

- Allow message frame duration to vary according to the contents; no Pause pulse is applied. (SENT_UPDATE = 0)
- The device sends messages with constant duration. If a particular message is shorter, a Pause pulse is inserted with a length that completes the message period. (SENT_UPDATE = 1)
- Synchronize the message frame transmission rate with the A1341 internal update rate (set by BW value) by inserting a calculated Pause pulse to complete required period. (SENT_UPDATE = 2)

Figures 16, 17, and 18 show examples of the timing relationship between SENT message Pause pulse configurations and the internal update rate of the A1341.

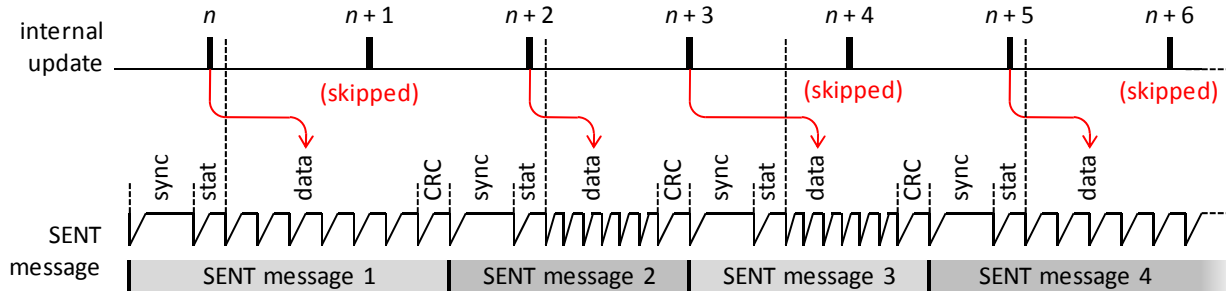

Figure 16: Messages Do not Contain a Pause Pulse (SENT_UPDATE = 0)

Messages do not contain a Pause pulse (SENT_UPDATE = 0), so the SENT message frame rate is not constant. The value transmitted in a message is taken from the last internal update ready before the first Data nibble of the message is composed. Therefore, individual internal updates may be skipped or repeated, depending on the BW bandwidth and SENT_TICK time settings.

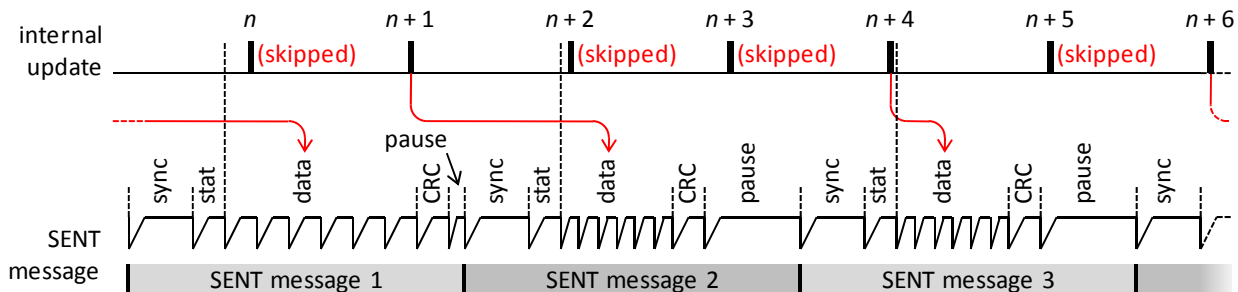
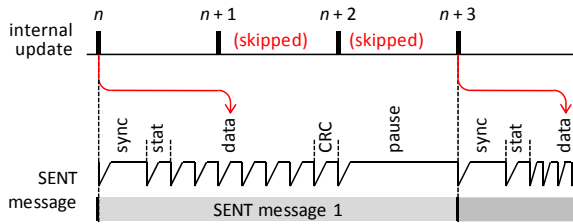

Figure 17: Pause Pulse Used to Extend the Message to Match the Frame Rate (SENT_UPDATE = 1)

A constant message frame rate is used, and for each message, a Pause pulse is used to extend the message to match the frame rate (SENT_UPDATE = 1). Internal updates may be skipped or repeated depending on the BW bandwidth and SENT_TICK time settings. The quantity of skipped or repeated internal updates can vary from message to message.

Note: Although the frame transmission rate is constant, discrete SENT messages do not represent equal time interval sampling of the magnetic field.



Panel 18(a): The longest possible SENT message is synchronized at three times the internal update rate. The first update is ready before the synchronization nibble is composed, and is transmitted. Three more updates occur before the next SENT message, so only the third update data is included, and the two intervening updates are skipped.

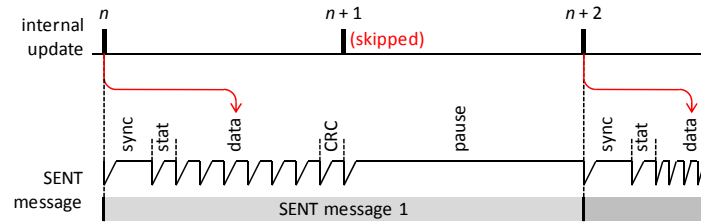

Panel 18(b): The filter bandwidth is reduced by twice relative to the bandwidth in panel (a), which doubles the internal update interval. The longest possible SENT message is now synchronized at two times the internal update rate. The first update is ready before the synchronization nibble is composed, and is transmitted. Two more updates occur before the next SENT message, so only the second update data is included, and the one intervening update is skipped.

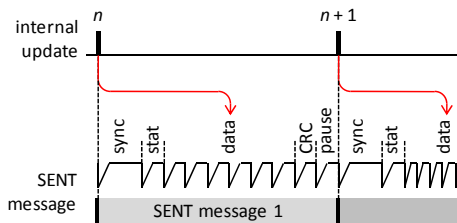

Panel 18(c): The internal update rate is the same as in panel (b), but the tick duration is reduced slightly. The longest possible SENT message is now synchronized at the internal update rate. Each update is ready before the synchronization nibble is composed, and is transmitted. No updates are skipped.

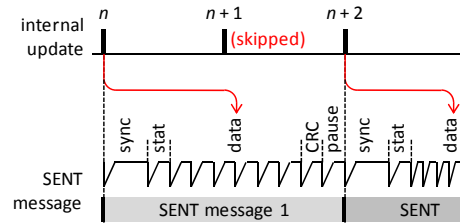

Panel 18(d): The faster update rate of panel (a) and the shorter tick duration of panel (c) are applied. Because the panel (d) higher bandwidth setting also applies, the overall A1341 response time is faster than that shown in panel (c). However, the panel (c) settings reduce front-end noise better than those of panel (d), because of the lower bandwidth.

Figure 18: SENT Message Rate Synchronized with the Internal A1341 Internal Update Rate.

For each message, a Pause pulse is used to extend the message to match the internal update rate (SENT_UPDATE = 2). A consistent number of updates are skipped or repeated from message to message. The internal update value transmitted is from the last update ready before the Synchronization and Calibration nibble of the message is composed.

The SENT_UPDATE parameter has two other options, which allow direct control of when magnetic field data is sent to the external controller:

- Tandem data latching and sending (SENT_UPDATE = 3)
- Immediate data latching with a controllable delay before sending (SENT_UPDATE = 4)

When SENT_UPDATE = 3 (upper panel in Figure 19), while the A1341 has a Pause pulse on the device output, the controller triggers a latch-and-send sequence by pulling the A1341 output low. When the controller releases the output, the current magnetic field data is latched, and after a delay of t_{dSENT} the latched data is sent to the controller. This option is useful when the controller

requires a prompt response on the current magnetic field.

When SENT_UPDATE = 4 (lower panel in Figure 19), while the A1341 has a Pause pulse on the device output, the controller triggers a latch-and-send sequence by pulling the output low. With this option, the current magnetic field data is latched immediately. This allows the controller to postpone receiving the data. When the output is eventually released, the data is sent to the controller after a delay of t_{dSENT} . This option is useful where multiple A1341s are connected to the controller (see Typical Application, Figure 8). All the A1341s can be instructed at the same time to latch magnetic field data, and the controller can then retrieve the data from each A1341 individually.

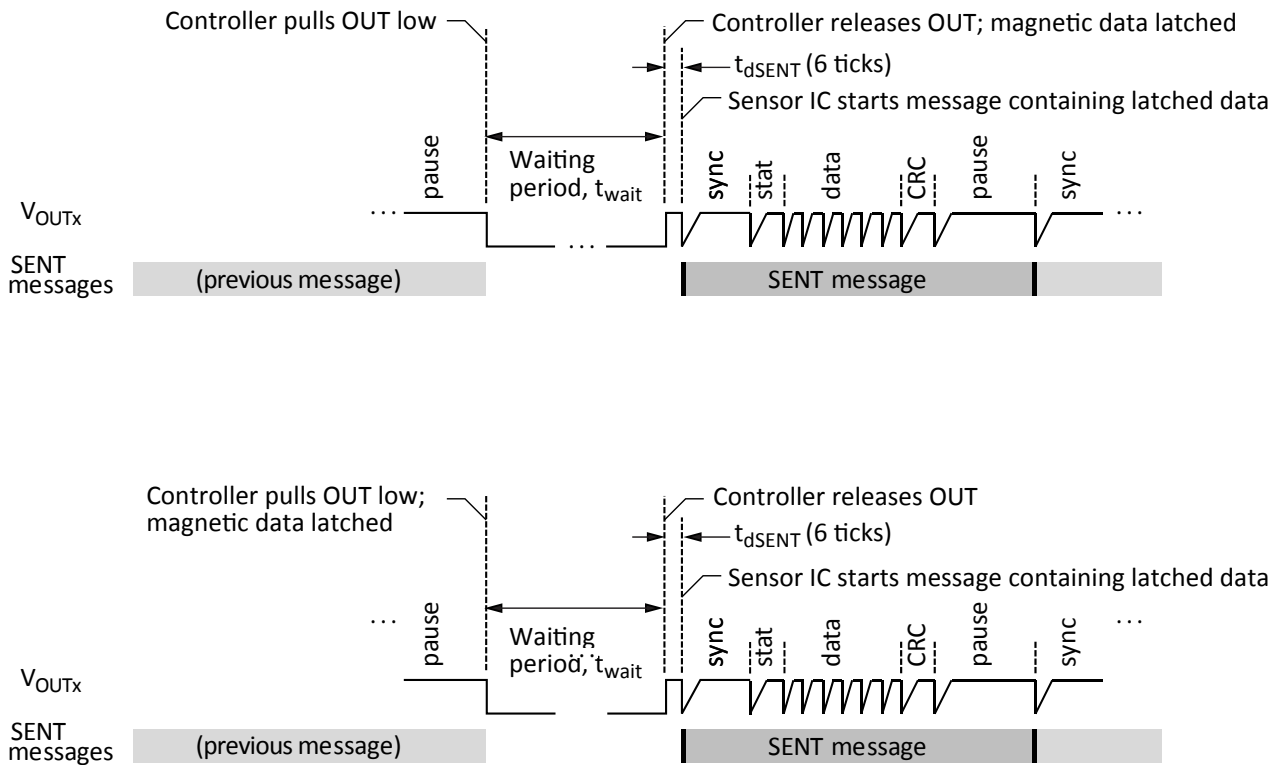

Figure 19: Device Output Behavior where Normal Operation Magnetic Field Data is Latched at a Defined Time (upper panel) if SENT_UPDATE = 3, latched and sent at end of a low pulse, or (lower panel) if SENT_UPDATE = 4, latched at the beginning of a low pulse, but not sent until the end of the pulse. The total delay from the beginning of the low pulse until the data message begins is: $t_{wait} + t_{dSENT}$.

The general format of a command message frame is shown in Figure 15. The individual sections of a SENT message are described in Table 13.

Table 13: SENT Message Frame Section Definitions

Section	Description
Synchronization and Calibration	
Function	Provide the external controller with a detectable start of the message frame. The large quantity of ticks distinguishes this section, for ease of distinction by the external controller.
Syntax	Nibbles: 1 Quantity of ticks: 56 Quantity of bits: 1
Status and Communication	
Function	Provides the external controller with the status of the A1341 and indicates the format and contents of the Data section.
Syntax	Nibbles: 1 Quantity of ticks: 12 to 27 Quantity of bits: 4 1:0 Device status (set by SENT_STATUS parameter) 3:2 Message serial data protocol (set by SENT_SERIAL parameter)
Data	
Function	Provides the external controller with data selected by the SENT_DATA parameter.
Syntax	Nibbles: 3 to 6 Quantity of ticks: 12 to 27 (each nibble) Quantity of bits: 4 (each nibble)
CRC	
Function	Provides the external controller with cyclic redundancy check (CRC) data for certain error detection routines applied to the Data nibbles.
Syntax	Nibbles: 1 Quantity of ticks: 12 to 27 (each nibble) Quantity of bits: 4
Pause Pulse	
Function	(Optional) Additional time can be added at the end of a SENT message frame to ensure all message frames are of appropriate length. The SENT_UPDATE parameter sets format.
Syntax	Nibbles: 1 Quantity of ticks: 12 minimum (length determined by SENT_UPDATE option and by the individual structure of each SENT message) Quantity of bits: n.a.

EEPROM STRUCTURE

Programmable values are stored in an onboard EEPROM, including both volatile and non-volatile registers. Although it is separate from the digital subsystem, it is accessed by the digital subsystem EEPROM Controller module.

The EEPROM is organized as 30-bit wide words, and by default each word has 24 data bits and 6 ECC (Error Checking and Correction) check bits, stored as shown in Figure 20.

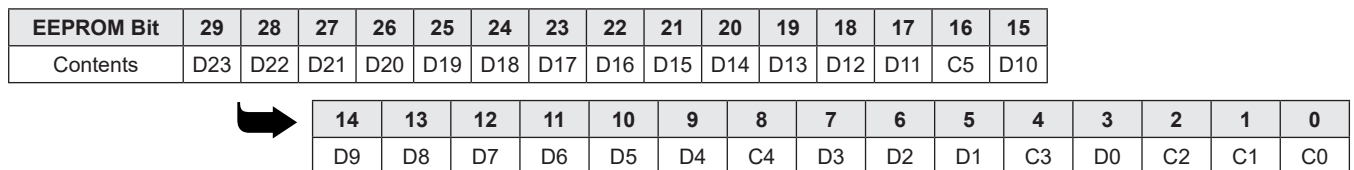

Figure 20: EEPROM Word Bit Sequence; C# – Check Bit, D# – Data Bit

Table 14: EEPROM Register Map of Customer-Programmable Parameters

Address	Bits	Parameter Name	Description	DAC profile
0x07	23:21	Reserved		
0x07	20:18	OUTDRV_CFG	Output Driver Setting	
0x07	17:0	SENTPWM_CFG	SENT and PWM output mode configuration parameters (assignment determined by PWM_MODE bit)	
	17:11	SENT_TICK	Sets Tick Rate Coefficient (PWM_MODE = 0)	
	10:9	SENT_FIXED	Sets Fixed State interval (PWM_MODE = 0)	
	8	SENT_LOVAR	Sets Fixed State Assignment (PWM_MODE = 0)	
	7:5	SENT_UPDATE	Sets Pause Pulse and Message Frame Rate (PWM_MODE = 0)	
	4:3	SENT_DATA	Sets Data Nibble Format (PWM_MODE = 0)	
	2	SENT_STATUS	Sets Error Condition (PWM_MODE = 0)	
	1:0	SENT_SERIAL	Sets Message Series Format (PWM_MODE = 0)	
	3	CALIBRATE_PWM	Enables 50% Duty Cycle Calibration (PWM_MODE = 1)	
	2:0	FPWM	Sets PWM Carrier Frequency (PWM_MODE = 1)	
0x08	23:15	TC2_SENS_HOT	2 nd Order Sensitivity Temperature Coefficient, ΔT (from 25°C) > 0	Two's complement
0x08	14:6	TC2_SENS_CLD	2 nd Order Sensitivity Temperature Coefficient, ΔT (from 25°C) < 0	Two's complement
0x08	5:2	SENS_COARSE	Factory Trimmed Magnetic Input Signal Range	Non-uniform
0x08	1:0	Reserved	Reserved for system use (bits written here will not affect device operation)	Non-uniform
0x09	23:16	TC1_SENS_HOT	1 st Order Sensitivity Temperature Coefficient, ΔT (from 25°C) > 0	Non-uniform
0x09	15:8	TC1_SENS_CLD	1 st Order Sensitivity Temperature Coefficient, ΔT (from 25°C) < 0	Non-uniform
0x09	7:0	TC1_OFFSET	1 st Order Magnetic Offset TC Compensation	Two's complement
0x0A	23:12	SCRATCH_C	Customer Scratchpad	
0x0A	11:0	SENS_MULT	Output Sensitivity/ Sensitivity Multiplier	
0x0B to 0x1A	23:12	LINPOS_COEFF (LIN_1, LIN_3, ..., LIN_31)	Linearization Coefficients (odd-numbered sampling positions)	Two's complement
0x0B to 0x1B	11:0	LINPOS_COEFF (LIN_0, LIN_2, ..., LIN_32)	Linearization Coefficients (even-numbered sampling positions)	Two's complement
0x1B	23	LIN_TABLE_DONE	Linearization Coefficients Loaded Flag	
0x1B	22	LIN_OUTPUT_INVERT	Linearization Output Polarity Inversion	
0x1B	21	LIN_INPUT_INVERT	Linearization Input Polarity Inversion	
0x1B	20:12	ID	Customer Identification Number	
0x1C	23:18	CLAMP_HIGH	Clamp Upper Limit	
0x1C	17:12	CLAMP_LOW	Clamp Lower Limit	
0x1C	11	EEPROM_LOCK ^[1]	Customer EEPROM Lock	
0x1C	10	OVLO_LO	Overvoltage Lockout Threshold	
0x1C	9	LVD_DIS	Low Voltage Detection Disable	
0x1C	8:4	SIG_OFFSET	Factory Trimmed Magnetic Offset Compensation (Coarse)	Two's complement
0x1C	3	PWM_MODE	Normal Operation Output Mode (SENT / PWM)	
0x1C	2:0	BW	Bandwidth	
0x1D	23:12	SCRATCH_C	Customer Scratchpad	
0x1D	11:0	QOUT_FINE	Fine Quiescent Output Duty Cycle	Two's complement

^[1] Customer EEPROM lock allows the customer to lock the EEPROM registers from any further changes for the life of the device. Memory reading is still possible after the EEPROM lock bit is set. In the case that a write command is sent to the device by accident after the EEPROM lock, the device needs to be repowered to be accessible again for memory read.

EEPROM Customer-Programmable Parameter Reference

Table 15: BW (Register Address: 0x1C, bits 2:0)

Function	Filter Bandwidth Selects the filter bandwidth (3-dB frequency) for the digitized applied magnetic field signal, applied when passed to the digital system after analog front-end processing. This selection also sets the internal update rate.		
Syntax	Quantity of bits: 3		
Related Commands	–		
Values	Code	A-to-D Converter Output Rate (Typical) (kHz)	Filter 3 dB Bandwidth (Typical) (Hz)
	000 (Default)	8	1500
	001	16	3000
	010 (Same)	8	1500
	011	4	750
	100	2	375
	101	1	188
	110 111	Factory Use Only Factory Use Only	– –
Options	–		
Examples	–		

Table 16: CALIBRATE_PWM (Register Address: 0x07, bit 3)

Function	PWM Calibration Sent at power-on, commands the device to calculate the PWM 50% duty cycle to the centerpoint of the Full Scale Output range.
Syntax	Quantity of bits: 1
Related Commands	PWM_MODE (see EEPROM Structure Section)
Values	0: Disable calibration (Default) 1: Enable calibration
Options	None
Examples	–

Table 17: CLAMP_HIGH (Register Address: 0x1C, bits 23:18)

Function	Clamp Upper Limit Sets the percentage of the upper half of the Full Scale Output signal passed through at the end of the Digital Signal Processing stage.
Syntax	Quantity of bits: 6
Related Commands	CLAMP_LOW
Values	000000: 100%FSO (PWM: 95% maximum duty cycle, SENT: 4095) (Default) 111111: 50.78%FSO (PWM: 50% duty cycle, SENT: 2047)
Options	The factory-programmed default, $OUT_{CLP(H)init}$, is used if this parameter is not set.
Examples	–

Table 18: CLAMP_LOW (Register Address: 0x1C, bits 17:12)

Function	Clamp Lower Limit Sets the percentage of the lower half of the Full Scale Output signal passed through at the end of the Digital Signal Processing stage.
Syntax	Quantity of bits: 6
Related Commands	CLAMP_HIGH
Values	000000: 0% FSO (PWM: 5% duty cycle, SENT: 0) (Default) 111111: 49.22% FSO (PWM: 50% duty cycle, SENT: 2047)
Options	The factory-programmed default, $OUT_{CLP(L)init}$, is used if this parameter is not set.
Examples	–

Table 19: EEPROM LOCK: Address 0x1C, bit 11

Function	Disables writing into the device memory
Syntax	Quantity of bits: 1
Related Commands	–
Values	0 (default) Default memory lock mechanism 1 Prevents any Read or Write transaction with the device
Options	Lock bit feature is enabled following a reset of the device power after setting the EEPROM LOCK bit.
Examples	Refer to Memory Locking Mechanisms section for more information.

Table 20: Customer_ID (Register Address: 0x1B, bits 20:12)

Function	Customer Identification Number Available register for identifying the A1341 for multiple-unit applications.
Syntax	Quantity of bits: 12
Related Commands	SCRATCH_C
Values	Free-form
Options	–
Examples	–
EEPROM Lock	

Table 21: FPWM (Register Address: 0x07, bits 2:0)

Function	PWM Carrier Frequency Sets the carrier frequency for PWM mode normal output (voltage response to applied magnetic field). Selected frequency determines maximum output resolution.		
Syntax	Quantity of bits: 3		
Related Commands	PWM_MODE (see EEPROM Structure Section)		
Values	Code	PWM Frequency (Typical) (kHz)	Maximum Output Resolution (bits)
	000 (Default)	0.125	12
	001	0.25	12
	010	0.5	12
	011	1	11
	100	2	10
	101	4	9
	110	0.125	12
111	0.125	12	
Options	–		
Examples	–		

Table 22: LIN_INPUT_INVERT (Register Address: 0x1B, bit 21)

Function	Inverts the polarity of the input signal before it is sent into the linearization block. This setting is effective only if LIN_TABLE_DONE is set to 1.
Syntax	Quantity of bits: 1
Related Commands	LIN_x, LIN_OUTPUT_INVERT
Values	0: No inversion of signal before input into the linearization block. (Default) 1: Input signal inverted before it is sent into the linearization block.
Options	–
Examples	–

Table 23: LIN_OUTPUT_INVERT (Register Address: 0x1B, bit 22)

Function	Inverts the polarity of the input signal after the linearization block. (Can be used to invert the output polarity without populating the linearization table.)
Syntax	Quantity of bits: 1
Related Commands	LINPOS_COEFF, LIN_INPUT_INVERT
Values	0: No inversion of signal after processing in the linearization block. (Default) 1: Input signal inverted after processing in the linearization block.
Options	–
Examples	–

Table 24: LINPOS_COEFF

(LIN_0, LIN_2, ..., LIN_32) (Register Address: 0x0B to 0x1B, bits 11:0)

(LIN_1, LIN_3, ..., LIN_31) (Register Address: 0x0B to 0x1A, bits 23:12)

Function	Linearization Coefficients These addresses are available to store customer-generated and loaded coefficients used for linearization of the temperature-compensated and offset digital signal. Note: These are not used by the device unless the LIN_TABLE_DONE bit is set.								
Syntax	Quantity of bits: 12 (each) LIN_x corresponds to Input Sample B _{INx} Coefficient data stored in two's complement format Values must be monotonically increasing								
Related Commands	LIN_INPUT_INVERT, LIN_OUTPUT_INVERT, LIN_TABLE_DONE								
Values	Calculated according to applied magnetic field								
Options	Input Sample	Output Position (%FSI)	EEPROM Address	Bits		Input Sample	Output Position (%FSI)	EEPROM Address	Bits
	B _{IN0}	100	0x0B	11:00		B _{IN16}	16/32	0x13	11:00
	B _{IN1}	31/32	0x0B	23:12		B _{IN17}	15/32	0x13	23:12
	B _{IN2}	30/32	0x0C	11:00		B _{IN18}	14/32	0x14	11:00
	B _{IN3}	29/32	0x0C	23:12		B _{IN19}	13/32	0x14	23:12
	B _{IN4}	28/32	0x0D	11:00		B _{IN20}	12/32	0x15	11:00
	B _{IN5}	27/32	0x0D	23:12		B _{IN21}	11/32	0x15	23:12
	B _{IN6}	26/32	0x0E	11:00		B _{IN22}	10/32	0x16	11:00
	B _{IN7}	25/32	0x0E	23:12		B _{IN23}	9/32	0x16	23:12
	B _{IN8}	24/32	0x0F	11:00		B _{IN24}	8/32	0x17	11:00
	B _{IN9}	23/32	0x0F	23:12		B _{IN25}	7/32	0x17	23:12
	B _{IN10}	22/32	0x10	11:00		B _{IN26}	6/32	0x18	11:00
	B _{IN11}	21/32	0x10	23:12		B _{IN27}	5/32	0x18	23:12
	B _{IN12}	20/32	0x11	11:00		B _{IN28}	4/32	0x19	11:00
	B _{IN13}	19/32	0x11	23:12		B _{IN29}	3/32	0x19	23:12
	B _{IN14}	18/32	0x12	11:00		B _{IN30}	2/32	0x1A	11:00
	B _{IN15}	17/32	0x12	23:12		B _{IN31}	1/32	0x1A	23:12
					B _{IN32}	0	0x1B	11:00	
Examples	-								

Table 25: LIN_TABLE_DONE (Register Address: 0x1B, bit 23)

Function	Linearization Table Loaded Set by the customer to indicate custom coefficients have been loaded (into the LINPOS_COEFF area of EEPROM). When this flag is set, the device uses the customer coefficients for output linearization. Allows correction for targets that generate non-linear magnetic fields.
Syntax	Quantity of bits: 1
Related Commands	LINPOS_COEFF
Values	0: Linearization algorithm applies default coefficients to the processed signal (Default) 1: Linearization algorithm applies customer-loaded coefficients to the processed signal
Options	–
Examples	–

Table 26: LVD_DIS: Address 0x1C bit 9

Function	Low Voltage Detection Disable Disable the low voltage detection feature.
Syntax	Quantity of bits: 1
Related Commands	–
Values	0: Default, Low Voltage Detection enabled. 1: Low Voltage Detection disabled.
Options	–
Examples	–

Table 27: OUTDRV_CFG (Register Address: 0x07, bits 20:18)

Function	Output Signal Configuration Sets configuration of the output signal slew-rate control. Sets the ramp rate on the gate of the output driver, thereby changing slew rate at the output.			
Syntax	Quantity of bits: 3			
Related Commands	–			
Values		Fall Time (Typical) (μ s)		
	Code	$C_{LOAD} = 100$ pF	$C_{LOAD} = 1$ nF	$C_{LOAD} = 10$ nF
	000 (Default)	0.048	0.149	1.324
	001	0.114	0.217	1.323
	010	0.202	0.309	1.404
	011	0.290	0.400	1.492
	100	0.760	0.854	1.948
	101	1.539	1.555	2.669
	110	3.161	2.978	4.118
111	4.819	4.442	5.557	
Options	–			
Examples	–			

Table 28: OVLO_LO (Register Address: 0x1C, bit 10)

Function	Overvoltage Lockout Threshold Sets the typical threshold value.
Syntax	Quantity of bits: 1
Related Commands	–
Values	0: 19.3 V typical (Default) 1: 6.5 V typical
Options	–
Examples	–

Table 29: PWM_MODE (Register Address: 0x1C, bit 3)

Function	Normal Operation Output Mode Changes normal output (voltage response to applied magnetic field) from SENT to PWM.
Syntax	Quantity of bits: 1
Related Commands	CALIBRATE_PWM, FPWM
Values	0: SENT (Default) 1: PWM
Options	–
Examples	–

Table 30: QOUT_FINE (Register Address: 0x1D, bits 11:0)

Function	Quiescent Output (QOUT) Adjusts the device normal output (digital response to applied magnetic field) to set the baseline output level: for a quiescent applied magnetic field ($B_{IN} \approx 0$ G).
Syntax	Quantity of bits: 12 Code stored in two's complement format
Related Commands	SIG_OFFSET
Values	0111 1111 1111: +49.98% of output full scale range (Default) 1000 0000 0000: –50% of output full scale range
Options	The factory-programmed default, QOUT, is used if this parameter is not set.
Examples	–

Table 31: SCRATCH_C (Register Address: 0x1D, bits 23:12)

Function	Customer Scratchpad For optional customer use in storing values in the device.
Syntax	Quantity of bits: 12 Two independent locations
Related Commands	IC
Values	Free-form field
Options	–
Examples	–

Table 32: SENS_COARSE (Register Address: 0x08, bits 5:2)

Offset drifts with temperature changes will be altered from the factory programmed values after the Coarse Sensitivity is changed. If a change in Coarse Sensitivity is unavoidable, please contact Allegro for detailed information.

Function	Coarse Sensitivity Sets the nominal (coarse) sensitivity of the device, SENS_COARSE, which can be defined as $OUT/\Delta B_{IN}$. Selection determines the RANGE, the extent of the applied magnetic flux intensity, B_{IN} , sampled for signal processing. (Use SIG_OFFSET to adjust the B_{IN} level at which RANGE is centered.)		
Syntax	Quantity of bits: 4		
Related Commands	SIG_OFFSET, SENS_MULT		
Values	Code	Coarse Sensitivity at $V_{CC} = 5\text{ V}$ (Typical) (%FSO/G)	RANGE (Typical) (G)
	0000 (Default)	0.100	±500
	0001	0.333	±150
	0010	0.250	±200
	0011	0.200	±250
	0100	0.167	±300
	0101	0.125	±400
	0110	0.080	±625
	0111	0.067	±750
	1000	0.057	±875
	1001	0.050	±1000
	1010	0.040	±1250
	1011	0.033	±1500
	1100	0.029	±1750
	1101	0.025	±2000
	1110	0.5	±100
1111	0.022	±2250	
Options	The default, SENS = 0.1%FSO/G for SENS_COARSE and $B_{IN} = \pm 500\text{ G}$ for RANGE are used if this parameter is not set. Output accuracy is reduced with codes 1110 and 1111.		
Examples	To set a sampled B_{IN} range of 500 G, set RANGE = ±250 G (SENS_COARSE = 0011). That would also set Coarse Sensitivity to 0.2%FSO/G (SENS_COARSE = 0011).		

Table 33: SENS_MULT (Register Address: 0x0A, bits 11:0)

Function	Sensitivity Multiplier After temperature compensation, establishes the gain of the device in normal output (response to a change in the applied magnetic field) by indicating a multiplier value.
Syntax	Quantity of bits: 12 The SENS_MULT values are mapped to the programming code values as follows: 
Related Commands	RANGE (SENS_COARSE), TC1_SENS_CLD, TC1_SENS_HOT, TC2_SENS_CLD, TC2_SENS_HOT
Values	–
Options	SENS_OUT = SENS_COARSE, that is, SENS_MULT = 1 (code 0) if this parameter is not set.
Examples	At: RANGE = ±500 G, SENS_COARSE code and available range: 0000: 0.1%FS/G nominal SENS_MULT maximum code gives 0.2%FSO/G nominal

Table 34: SENT_DATA (Register Address: 0x07, bits 4:3)

Function	Data Nibble Format Quantity and contents of Data nibbles in message. (Does not relate to data contained in the Status and Communication nibble.)
Syntax	Quantity of Bits: 2
Related Commands	–
Values	0 0: Nibbles 1,2,3: magnetic field data; nibbles 4,5: counter data; nibble 6: inverted nibble 1 (Default) 0 1: Nibbles 1,2,3: magnetic field data; nibbles 4,5: counter data; nibble 6: all zeros 1 0: Nibbles 1,2,3: magnetic field data; nibbles 4,5,6: current temperature data 1 1: Nibbles 1,2,3: magnetic field data (nibbles 4,5,6 skipped)
Options	–
Examples	–

Table 35: SENT_FIXED (Register Address: 0x07, bits 10:9)

Function	Fixed Interval Duration Indicates the quantity of ticks in fixed-duration intervals.
Syntax	Quantity of Bits: 2
Related Commands	SENT_LOVAR
Values	0 0: 5 ticks (Default) 0 1: 4 ticks 1 0: 7 ticks 1 1: 8 ticks
Options	SENT_FIXED = 1 (4 ticks) does not meet the SENT spec, but is provided for custom fast or improved-EMI communication.
Examples	–

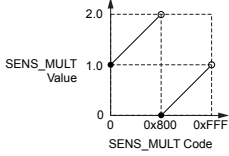
Table 36: SENT_LOVAR (Register Address: 0x07, bit 8)

Function	State Assignments Assigns fixed duration state (becomes delimiting state; other interval becomes the information state)
Syntax	Quantity of Bits: 1
Related Commands	SENT_FIXED
Values	0: Low interval of every nibble is fixed in duration, and the high interval becomes the information state (Default) 1: High interval of every nibble is fixed in duration, and the low interval becomes the information state
Options	SENT_LOVAR = 0 meets the SENT specification. SENT_LOVAR = 1 does not meet the SENT spec, but is provided for custom improved-EMI communication. For SENT_UPDATE = 3 or 4, the Pause pulse has a fixed low time regardless of the SENT_LOVAR setting.
Examples	–

Table 37: SENT_SERIAL (Register Address: 0x07, bits 1:0)

Function	Status and Communication Nibble Format Defines values of bits 2 and 3 inside the Status and Communication nibble.
Syntax	Quantity of Bits: 2
Related Commands	–
Values	0 0: Bits 2 and 3 are 0 (Default) 0 1: Bits 2 and 3 are 0 part of the Short Serial protocol: 8-bit value data, 4-bit message ID, 16 SENT frames are required to send an entire serial message 1 0: Bits 2 and 3 are part of the Enhanced 16-bit Serial protocol: 12-bit value data, 4-bit message ID, 18 SENT frames are required to send an entire serial message 1 1: Bits 2 and 3 are part of the Enhanced 24-bit Serial protocol: 16-bit value data, 8-bit message ID, 18 SENT frames are required to send an entire serial message
Options	–
Examples	–

Table 38: SENT_STATUS (Register Address: 0x07, bit 2)

Function	Error Condition Status Defines values of bits 0 and 1 inside the Status and Communication nibble. Defines data inside the Status and Communication nibble on device error status.
Syntax	Quantity of Bits: 1
Related Commands	SENT_SERIAL
Values	(SENT_STATUS = 0) 0 0: No error (Default) 0 1: Not used 1 0: Overvoltage condition 1 1: Nonrecoverable EEPROM error, bad Linearization table or other error (SENT_STATUS = 1) 0 0: No error (Default) 0 1: Error condition
Options	–
Examples	A Status and Communication nibble value of 0010 indicates an overvoltage condition.

Table 39: SENT_TICK (Register Address: 0x07, bits 17:11)

Function	Tick Duration Sets the SENT tick rate coefficient: $4 \text{ MHz} / \text{SENT_TICK} = \text{tick} (\mu\text{s})$		
Syntax	Quantity of Bits: 7 Any value from 0 to 127 can be used		
Related Commands	–		
Values	Code	PWM Frequency (Typical) (μs)	Coefficient (MHz/SENT_TICK)
	000 0000	3.0 (Default)	4/12
	000 0001	0.25	4/1
	000 0010	0.5	4/2
	000 0111	0.75	4/3
	111 1111	32	4/125
	111 1110	31.5	4/126
	111 1111	31.75	4/127
Options	SENT_TICK = 1 through 11 do not meet the SENT spec, but are provided for custom fast communication.		
Examples	–		

Table 40: SENT_UPDATE (Register Address: 0x07, bits 7:5)

Function	Pause Pulse and Frame Rate Pause pulse usage and message frame rate.
Syntax	Quantity of Bits: 3
Related Commands	SENT_LOVAR
Values	000: No Pause pulse; new frame immediately follows previous frame (Default)
	001: Pause pulse used for minimum constant frame rate (Length of other message sections, plus length of Pause Pulse nibble, is constant. For the maximum message length, Pause pulse information state is the minimum size of 12 ticks.)
	010: Pause pulse used for constant frame rate, synchronized with A1341 internal update rate. (Handshaking occurs such that the Synchronization and Calibration nibble starts immediately after the next new data word is ready.)
	011: Pause pulse held indefinitely until receipt of trigger pulse (OUT pulled low) from the controller, data latched after output released and message is sent.
	100: Pause pulse held indefinitely until receipt of trigger pulse (OUT pulled low) from the controller, data latched immediately and sent when output is released.
	101, 110, 111: Same function as 000.
Options	–
Examples	–

Table 41: SIG_OFFSET (Register Address: 0x1C, bits 8:4)

If changing Coarse Magnetic Offset cannot be avoided because of application requirements, please contact Allegro for detailed information.

Function	Magnetic Offset Compensation (Coarse) Adjusts the center of the selected B_{IN} range (SIG_OFFSET) to adapt to the application magnetic field.	
Syntax	Quantity of bits: 5 Code stored in two's complement format.	
Related Commands	RANGE, TC1_OFFSET	
Values	Code	SIG_OFFSET (% of Full-Scale RANGE)
	0000 (Default)	0.00
	00001	6.25
	00010	12.50
	00011	18.75
	00100	25.00
	00101	31.25
	00110	37.50
	00111	43.75
	01000	50.00
	01001	56.25
	01010	62.75
	01011	68.75
	01100	75.00
	01101	81.25
	01110	87.50
	01111	93.75
	10000	-100.00
	10001	-93.75
	10010	-87.50
	10011	-81.25
	10100	-75.00
	10101	-68.75
	10110	-62.50
10111	-56.25	
11000	-50.00	
11001	-43.75	
11010	-37.50	
11011	-31.25	
11100	-25.00	
11101	-18.75	
11110	-12.50	
11111	-6.25	
Options	The default, QOUT, is used if this parameter is not set.	
Examples	<p>To set the input range from 0 to 1000 G, with a centerpoint at +500 G:</p> <ol style="list-style-type: none"> 1. Leave SENS_COARSE at 0.1%FSO/G (SENS_COARSE code = 0000). This establishes a full scale input RANGE of 1000 G. 2. The full scale input value, 1000 G, is used as the start point of the offset, so: $\text{SIG_Offset} = (\text{Centerpoint} - \text{Full scale input}) / \text{Full scale input}$ $= 100 \times (500 - 1000) / 1000 = -50\%$ 3. Set the SIG_OFFSET code to 11000 (24), to select SIG_OFFSET = -50%. 	

Table 42: TC1_OFFSET (Register Address: 0x09, bits 7:0)

Function	1st Order Magnetic Offset Temperature Compensation coefficient
Syntax	Quantity of bits: 8 Code stored in two's complement format.
Related Commands	SIG_OFFSET, TC1_SENS_CLD, TC1_SENS_HOT, TC2_SENS_CLD, TC2_SENS_HOT
Values	0000 0000: Default 0111 1111: +0.48 G/°C 1000 0000: -0.48 G/°C
Options	No fine magnetic offset is applied if this parameter is not set.
Examples	–

Table 43: TC1_SENS_CLD (Register Address: 0x09, bits 15:8)
TC1_SENS_HOT (Register Address: 0x09, bits 23:16)

Function	1st Order Sensitivity Temperature Coefficient. Specifies a compensation factor for drift in device Sensitivity resulting from changes in ambient temperature during operation. Applies a 1st order, linear compensation algorithm. Two different parameters are set, one for increasing values relative to $T_A = 25^\circ\text{C}$, and the other for decreasing values, as follows: <ul style="list-style-type: none"> • TC1_SENS_HOT: ΔT_A (from 25°C) > 0 • TC1_SENS_CLD: ΔT_A (from 25°C) < 0
Syntax	Quantity of bits: 8 (each parameter)
Related Commands	SENS_MULT, TC2_SENS_HOT, TC2_SENS_CLD
Values	0000 0000: -98 m%/°C 1111 1111: +291 m%/°C Increments (step size) of ± 1.53 m%/°C
Options	Set all bits to 0 if TC1_SENS_HOT and TC1_SENS_CLD are not used.
Examples	Refer to Temperature Compensation section.

Table 44: TC2_SENS_CLD (Register Address: 0x08, bits 14:6)
TC2_SENS_HOT (Register Address: 0x08, bits 23:15)

Function	2nd Order Sensitivity Temperature Coefficient. Specifies a compensation factor for drift in device Sensitivity resulting from changes in ambient temperature during operation. Applies a 2nd order, quadratic compensation algorithm. Two different parameters are set, one for increasing values relative to $T_A = 25^\circ\text{C}$, and the other for decreasing values, as follows: <ul style="list-style-type: none"> • TC2_SENS_HOT: ΔT (from 25°C) > 0 • TC2_SENS_CLD: ΔT (from 25°C) < 0
Syntax	Quantity of bits: 9 (each parameter)
Related Commands	SENS_MULT, TC1_SENS_HOT, TC1_SENS_CLD
Values	0 0000 0000: -1.53 m%/°C 1 1111 1111: +1.53 m%/°C Increments (step size) of ± 0.00596 m%/°C
Options	Set all bits to 0 if TC2_SENS_HOT and TC2_SENS_CLD are not used.
Examples	Refer to Temperature Compensation section.

DEFINITION OF TERMS

Full Scale (FSI and FSO)

Full Scale Input, FSI, is the range of the applied magnetic field processed by the device. Full Scale Output, FSO, is the range of output values that device output can have for the applied magnetic field. If device output is configured as PWM, output will be 5% and 95%. If device output is configured as SENT, device output will obtain LSB values from 0 to 4095. See Figure 21.

Power-On Time (t_{PO})

The time required for device output to generate either the first valid output message frame (SENT mode) or the first valid duty cycle (PWM mode), after the power supply has reached its minimum specified operating voltage, $V_{CC(min)}$. When the supply is ramped to its operating voltage, the device requires a finite time to power internal circuits before supplying a valid output value.

Signal Propagation Delay (t_{PROP})

The time necessary for the device to respond to an input magnetic change and to create a valid output message.

Signal Response Time (t_{RESP})

Typically Signal Response Time is defined as propagation delay plus length of the SENT/PWM message. However if filter bandwidth is chosen such that the corresponding internal output update rate (see BW parameter in EEPROM) is slower than the output digital message length, it might take a couple of output messages to update the user.

Quiescent Output (QOUT)

The output value in the quiescent state (when no magnetic field is applied, $B_{IN} = 0$ G).

The central portion of the programmable range for Quiescent Output, QOUT, range lies within the QOUT limits. The Quiescent Output, QOUT, can be customer-programmed around its typical value, which is 0 LSB (SENT mode) or 50% duty cycle (PWM mode).

Quiescent Output Drift Through Temperature Range

Due to internal component tolerances and thermal considerations, the temperature coefficient used to determine Quiescent Output may drift from its typical initial value, $OUT_{(Q)}$, when changes occur in the operating ambient temperature, T_A . For purposes of specification, the Quiescent Output Drift Through Temperature Range, $\Delta OUT_{(Q)}$, is defined as:

$$\Delta OUT_{(Q)} = OUT_{(Q)TA} - OUT_{(Q)25^{\circ}C} \quad (5)$$

where $OUT_{(Q)TA}$ is the $OUT_{(Q)}$ at a given T_A and $OUT_{(Q)25^{\circ}C}$ is the $OUT_{(Q)}$ at a T_A of $25^{\circ}C$. Note that $\Delta OUT_{(Q)}$ should be calculated using actual measured values, rather than target values used when programming.

The Offset Temperature Coefficient can be seen as representation of the offset drift over temperature in units $\%/C$:

$$\Delta OUT_{(Q)} = \frac{(OUT_{(Q)TA} - OUT_{(Q)25^{\circ}C}) / OUT_{(Q)25^{\circ}C}}{\Delta T_A} \times 100 \quad (6)$$

where $\Delta T_A = T_A - 25^{\circ}C$.

Sensitivity (Sens)

The proportion of the output voltage to the magnitude of the applied magnetic field. This proportionality is specified as the Sensitivity, Sens ($\Delta LSB/G$ for SENT mode, $\Delta D/G$ for PWM mode), and is effectively the gain of the device.

An individual A1341 device may be *unipolar*, and respond to the presence of either a south (positive) polarity magnetic field, or a north (negative) polarity magnetic field (but not both). Or it may be *bipolar*, and respond to both polarities. If responsive to a south field, a south field opposite and perpendicular to the branded face of the package will increase the output from its quiescent value toward the maximum output limit. If responsive to a north field, a north field opposite and perpendicular to the branded face of the

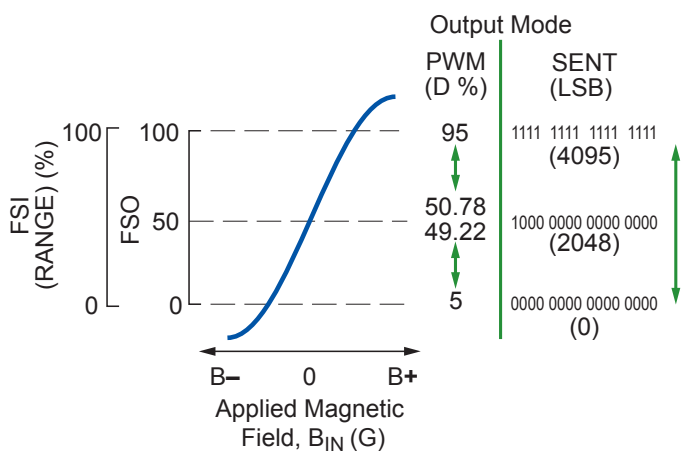

Figure 21: Full Scale Input (FSI) and Full Scale Output (FSO)

package will decrease the output from its quiescent value.

For bipolar configurations, Sensitivity is defined as:

$$\text{Sens} = \frac{\text{OUT}_{(\text{BPOS})} - \text{OUT}_{(\text{BNEG})}}{B_{\text{POS}} - B_{\text{NEG}}}, \quad (7)$$

and for unipolar configurations (south field responsive) as:

$$\text{Sens} = \frac{\text{OUT}_{(\text{BPOS})} - \text{OUT}_{(\text{Q})}}{B_{\text{POS}}}, \quad (8)$$

where B_{POS} and B_{NEG} are two magnetic fields with the indicated opposite polarities.

Sensitivity Drift Through Temperature Range

Due to internal component tolerances and thermal considerations, the temperature coefficient used to determine Sensitivity may drift from its typical initial value, $\text{Sens}_{\text{TCinit}}$, and the expected value after customer programming (EEPROM parameters TC1_SENS_CLD , TC1_SENS_HOT , TC2_SENS_CLD , TC2_SENS_HOT) when changes occur in the operating ambient temperature, T_A . For purposes of specification, the Sensitivity Drift Through Temperature Range, $\Delta\text{Sens}_{\text{TC}}$, is defined as:

$$\Delta\text{Sens}_{\text{TC}} = \frac{\text{Sens}_{T_A} - \text{Sens}_{\text{EXPECTED}(T_A)}}{\text{Sens}_{\text{EXPECTED}(T_A)}} \times 100 (\%) \quad (9)$$

where Sens_{T_A} is the actual Sens at the current ambient temperature, and $\text{Sens}_{\text{EXPECTED}(T_A)}$ is the Sens calculated based on programmed parameters.

Sensitivity Temperature Coefficient can be seen as a representation of the Sensitivity drift in $\%/^{\circ}\text{C}$ when a temperature divider, $\Delta T = T_A - 25^{\circ}\text{C}$, is inserted into equation 9.

Sensitivity Drift Due to Package Hysteresis ($\Delta\text{Sens}_{\text{PKG}}$)

Package stress and relaxation can cause the device sensitivity at $T_A = 25^{\circ}\text{C}$ to change during and after temperature cycling. For

purposes of specification, the Sensitivity Drift Due to Package Hysteresis, is defined as:

$$\Delta\text{Sens}_{\text{PKG}} = \frac{\text{Sens}_{(25^{\circ}\text{C})2} - \text{Sens}_{(25^{\circ}\text{C})1}}{\text{Sens}_{(25^{\circ}\text{C})1}} \times 100 (\%) \quad (10)$$

where $\text{Sens}_{(25^{\circ}\text{C})1}$ is the programmed value of Sensitivity at $T_A = 25^{\circ}\text{C}$, and $\text{Sens}_{(25^{\circ}\text{C})2}$ is the value of Sensitivity at $T_A = 25^{\circ}\text{C}$, after temperature cycling.

Linearity Sensitivity Error

The A1341 is designed to provide a linear output in response to a ramping applied magnetic field. Consider two magnetic field strengths, B_1 and B_2 . Ideally, the sensitivity of a device is the same for both field strengths, for a given supply voltage and temperature. Linearity error is present when there is a difference between the sensitivities measured at B_1 and B_2 .

Linearity Error is calculated separately for the positive (LinERRPOS) and negative (LinERRNEG) applied magnetic fields. Linearity error is measured and defined as:

$$\text{LinERRPOS} = \left(1 - \frac{\text{Sens}_{B_x}}{\text{Sens}_{B_x/2}} \right) \times 100 (\%) \quad (11)$$

$$\text{LinERRNEG} = \left(1 - \frac{\text{Sens}_{-B_x}}{\text{Sens}_{-B_x/2}} \right) \times 100 (\%)$$

where:

$$\text{Sens}_{B_x} = \frac{|\text{OUT}_{(B_x)} - \text{OUT}_{(Q)}|}{B_x} \quad (12)$$

and B_x and $-B_x$ are positive and negative magnetic fields

Final Linearity Sensitivity Error (LinERR) is the maximum value of the absolute positive and absolute negative linearization errors. Note that unipolar devices only have positive linearity error (LinERRPOS).

PACKAGE OUTLINE DRAWING

For Reference Only - Not for Tooling Use

(Reference DWG-9202)

Dimensions in millimeters - NOT TO SCALE

Dimensions exclusive of mold flash, gate burs, and dambar protrusions
Exact case and lead configuration at supplier discretion within limits shown

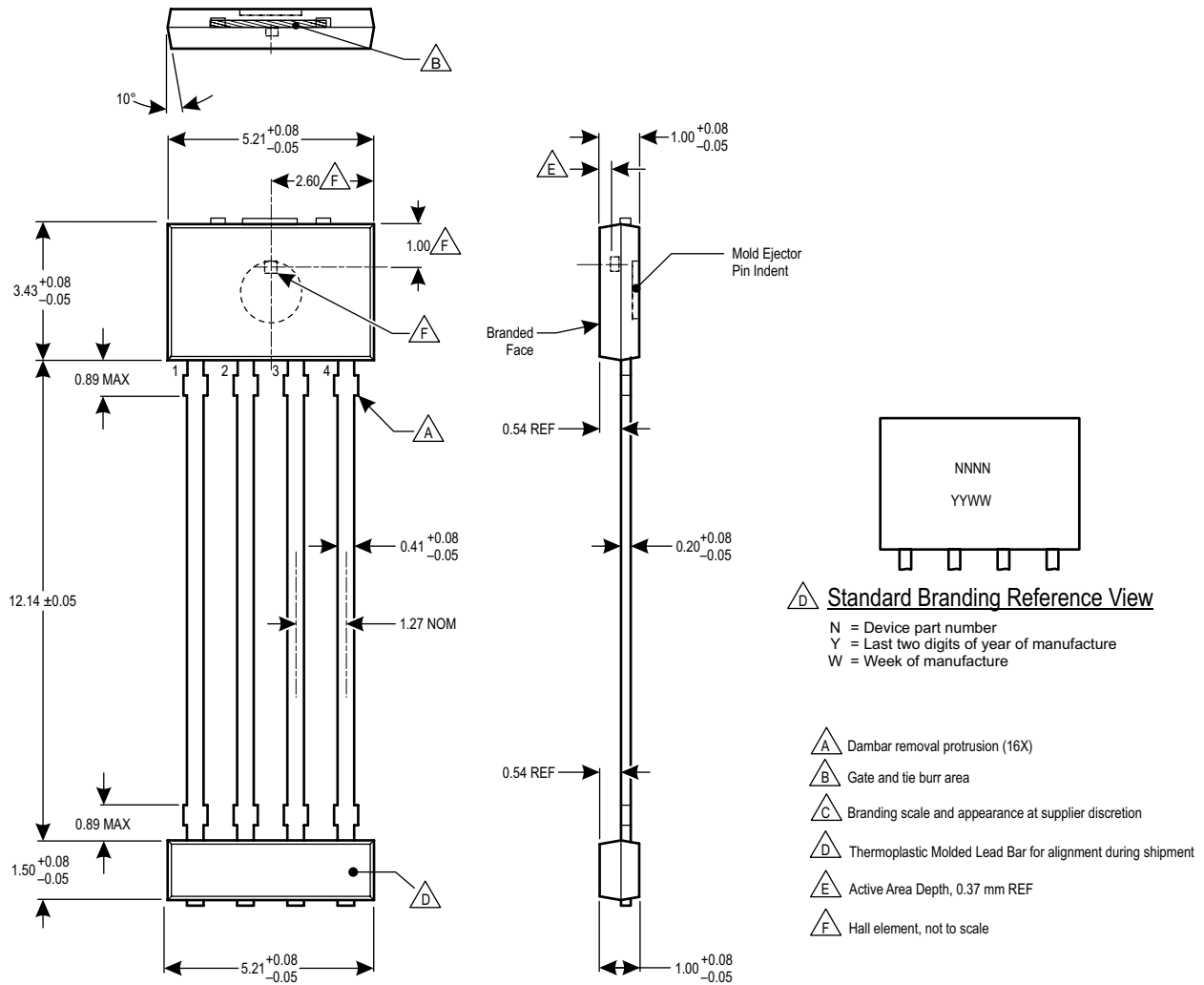

Package KT, 4-Pin SIP

Revision History

Number	Date	Description
–	November 13, 2014	Initial release
1	May 25, 2017	Updated Table 13: SENT Message Frame Section Definitions, CRC Function description (page 33).
2	January 4, 2018	Updated product status to not for new design
3	September 10, 2018	Updated product status to pre-end-of-life
4	January 25, 2019	Updated part status to last-time buy

Copyright 2019, Allegro MicroSystems.

Allegro MicroSystems reserves the right to make, from time to time, such departures from the detail specifications as may be required to permit improvements in the performance, reliability, or manufacturability of its products. Before placing an order, the user is cautioned to verify that the information being relied upon is current.

Allegro's products are not to be used in any devices or systems, including but not limited to life support devices or systems, in which a failure of Allegro's product can reasonably be expected to cause bodily harm.

The information included herein is believed to be accurate and reliable. However, Allegro MicroSystems assumes no responsibility for its use; nor for any infringement of patents or other rights of third parties which may result from its use.

Copies of this document are considered uncontrolled documents.

For the latest version of this document, visit our website:

www.allegromicro.com